

碳化硅衬底 加工设备介绍

SiC Substrate Introduction to
Processing Equipment

CONTENTS

目录

01

公司简介

COMPANY
PROFILE

02

碳化硅衬底工艺介绍

PROCESS
INTRODUCTION

03

碳化硅衬底设备介绍

EQUIPMENT
INTRODUCTION

04

特思迪优势

TSEMID
ADVANTAGE

01 PART ONE

公司简介

COMPANY PROFILE



01 公司介绍

COMPANY PORFILE

关于特思迪

北京特思迪半导体设备有限公司（简称“特思迪”）是一家为半导体衬底材料、晶圆制造、分立器件、先进封装等环节提供超精密平面技术的系统解决方案和工艺设备的高新技术企业，多次承担国家级、省级重大课题研究，目前已实现化合物半导体专用减薄、抛光设备的规模化量产。

半导体超精密平面技术专家

使命：引领半导体技术进步，助力客户发展

愿景：成为全球技术领先的半导体设备制造企业

经营理念：坚守科技匠心，坚持长期主义

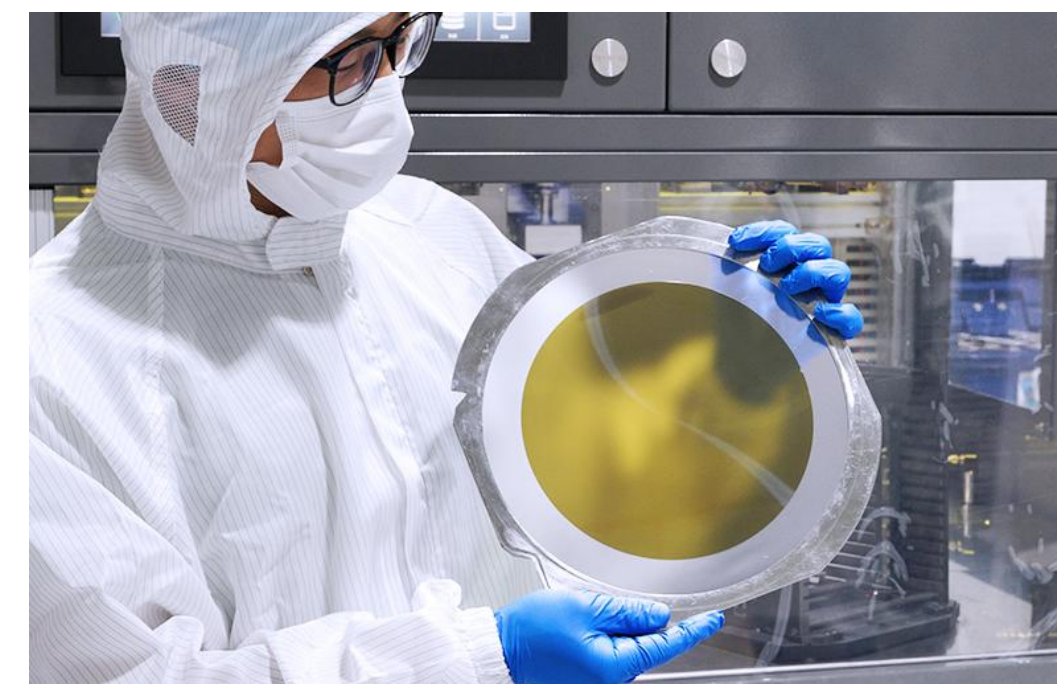

01 公司介绍

COMPANY PORFILE

化合物半导体专用减薄、抛光、CMP装备**国内唯一一家规模化量产企业**，在化合物半导体领域**市场占有率第一**。

替代进口，机台进入**华为、天科合达、天岳、烁科、同光、天域、比亚迪、方正微、长飞先进、瞻芯、泰科天润、瑞能、中电科13所、中电科 55所**等厂家，覆盖第二、三代半导体材料和器件。

碳化硅衬底加工经验丰富，**客户众多，市场占有率第一**

客户包括：天岳、天科合达、同光、烁科、比亚迪、三安、天域、中电化合物、东尼半导体、合盛、微芯长江、科友半导体、粤海金、晶越、露笑、超芯星、眉山天乐、晶格领域、中科院物理所等。

引领半导体技术进步 助力客户发展

特思迪以坚守科技匠心，坚持长期主义为经营理念，以领先的半导体平面技术，成就客户的核“芯”竞争力，带给产业无限可能。



01 公司介绍

COMPANY PORFILE

技术力量

公司现有员工270余人，本科及以上学历占比超过50%，技术研发人员70余人，拥有一批测量、光学、机械、自动化、软件和材料等学科高层次人才，核心部门员工均有半导体行业从业经验10年以上。

公司自建企业研发中心，围绕前沿技术布局和技术工艺转化组建实验室，由学科带头人进行研发管理。

- **朗途实验室：**专注于表面界面控制技术研发，重点解决相关基础理论应用问题，搭建超精密平面加工的基础理论研究与应用与关键技术突破的科研体系。
- **砺晶实验室：**专注于精密加工工艺的研究和开发，重点解决各类半导体材料的不同工艺问题，实现设备+工艺的整体解决方案。



实验室有各类先进的检测设备，满足半导体材料检测与表界面分析需求

01 公司介绍

COMPANY PORFILE

企业荣誉

国家高新技术企业

中关村高新技术企业

北京市专精特新中小企业

SEMI China会员单位

第三代半导体产业创新技术联盟理事单位

专利/实用新型/软著 100+

-国内发明专利25项

-国外发明专利6项

ISO三体系认证



01 公司介绍

COMPANY PORFILE

公司主要产品体系

减薄、抛光和CMP都属于材料超精密平面加工技术，是半导体制造不可或缺的环节，广泛应用于衬底材料、晶圆制造、封装等多个半导体制造环节。



衬底材料

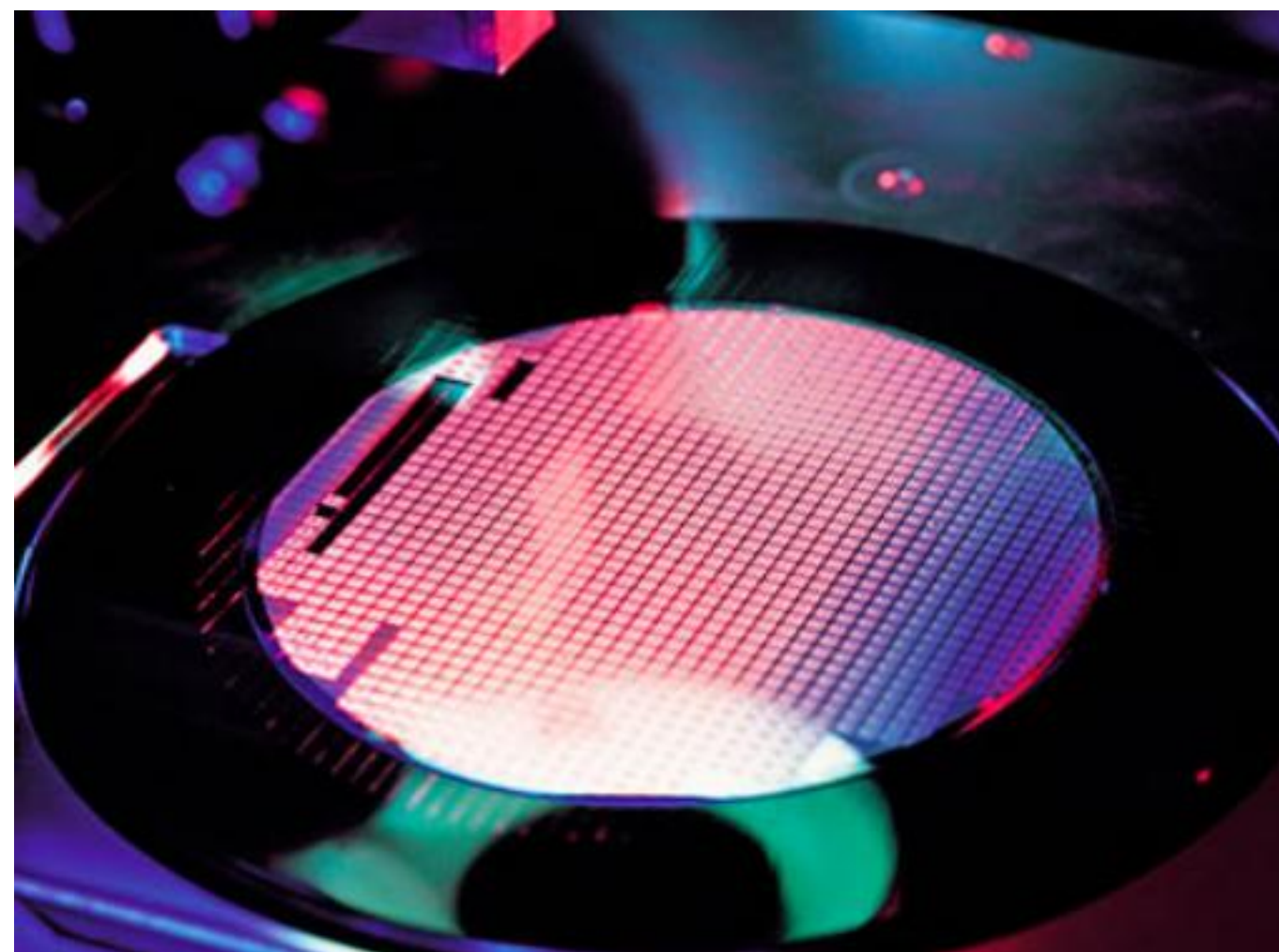

晶圆制造

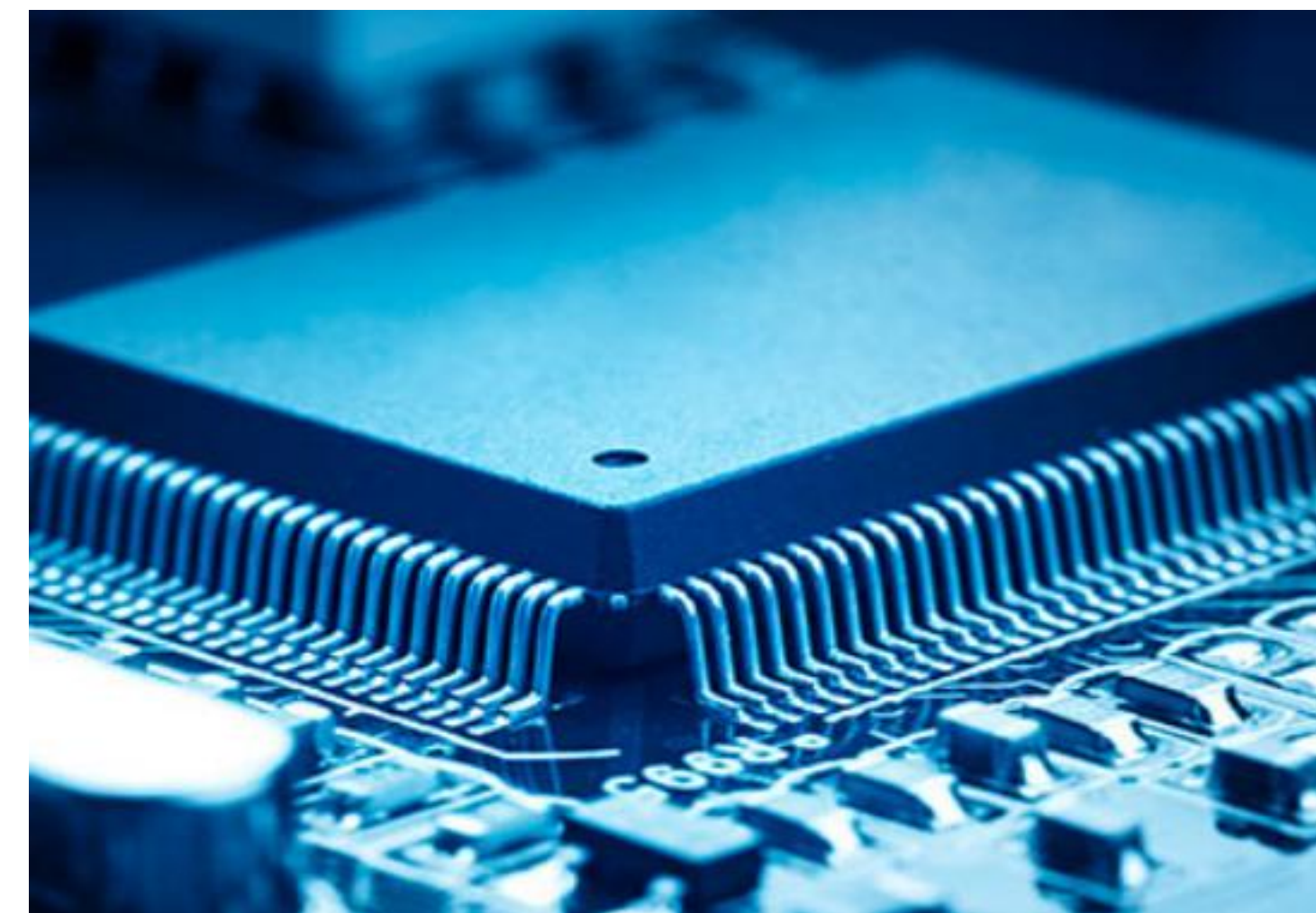

封装

01 公司介绍

COMPANY PORFILE

衬底抛光相关设备

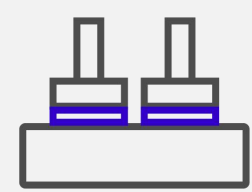

单抛设备

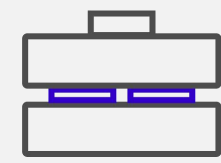

双抛设备



清洗设备

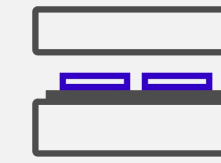

贴蜡设备

应用于各类半导体衬底材料:

Si、Ge、SiC、GaN、GaAs、InP、GaO、AlN、LT、LN、金刚石等衬底材料



双面抛光机



单面抛光机



单晶圆抛光机



晶圆刷洗机



陶瓷盘清洗机

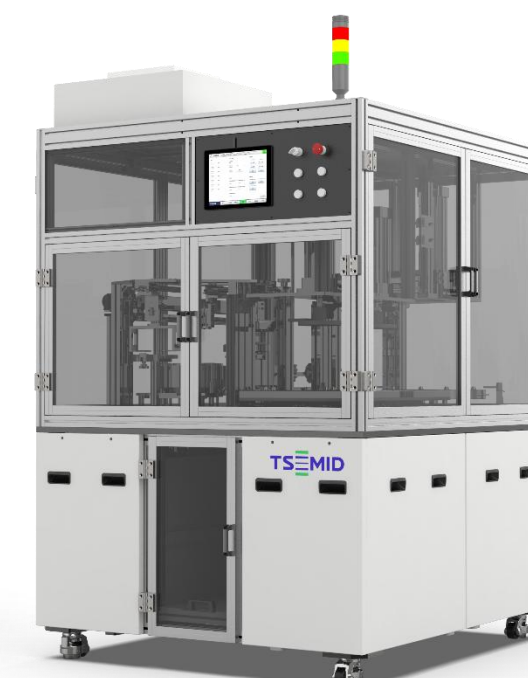

贴蜡机

01 公司介绍

COMPANY PORFILE

晶圆平坦化相关设备

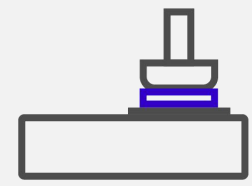

CMP系列



CMP后清洗设备

应用于各类半导体晶圆：

各类半导体集成电路、氧化物、金属、ILD、STI、SOI、TSV、MEMS等产品的平坦化抛光



手动CMP抛光机



半自动CMP抛光机



全自动CMP抛光机



CMP后清洗机

01 公司介绍

COMPANY PORFILE

晶圆薄化相关设备

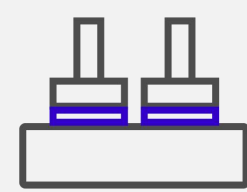

减薄设备

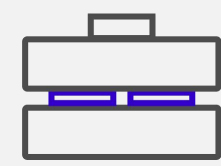

抛光设备



清洗设备

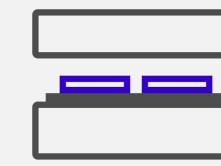

贴蜡设备

应用于各类半导体晶圆：

应用于Si、SiC、GaN、GaAs、InP、石英玻璃、LT、LN、CZT等各类半导体材料的减薄，应用于EMC晶圆、EMC Strip的研磨



减薄机



抛光机



清洗机

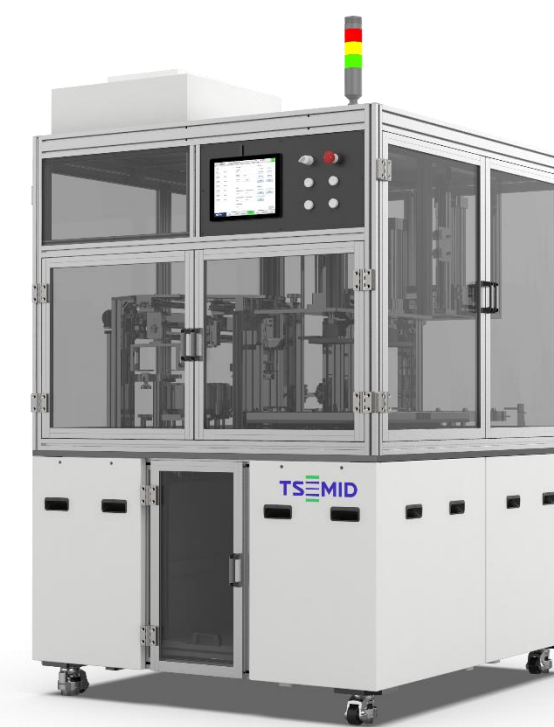

贴蜡机

02 PART TWO

碳化硅衬底 工艺介绍

PROCESS INTRODUCTION



02工艺介绍

PROCESS INTRODUCTION

工艺流程说明



长晶

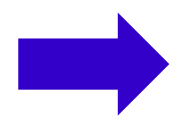

滚磨外圆

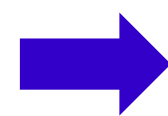

线切割

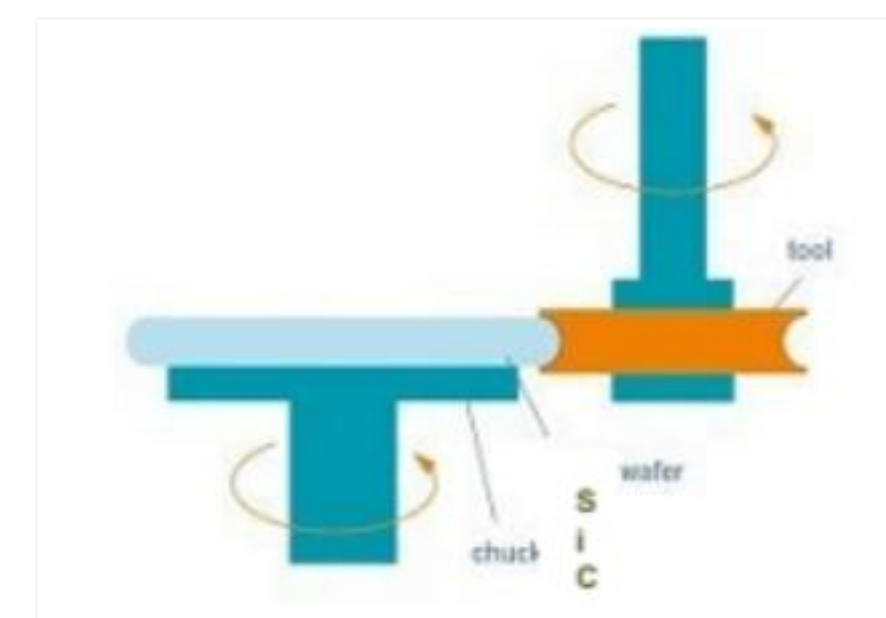
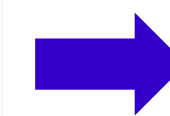

倒边

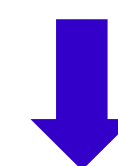

检测

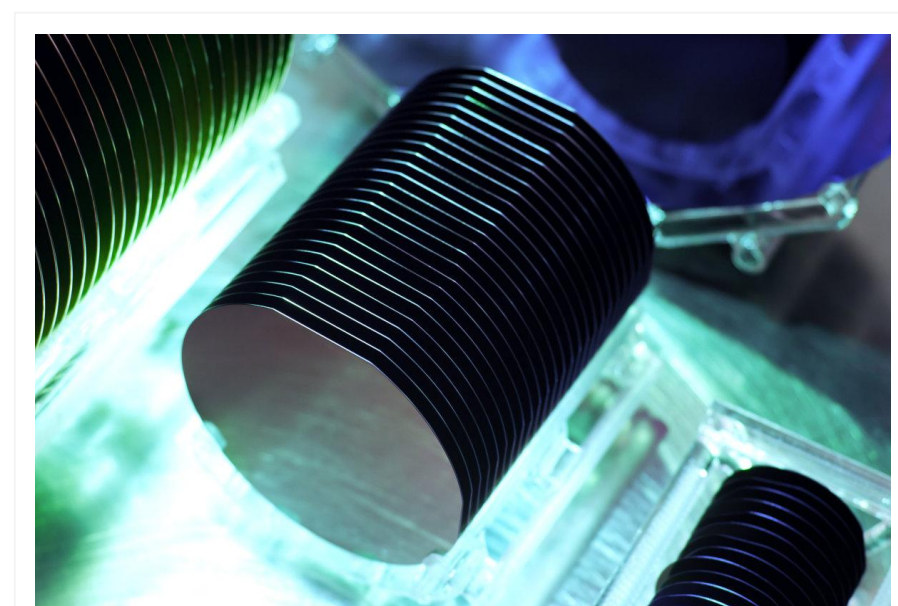
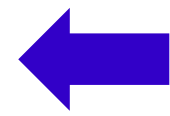

最终清洗

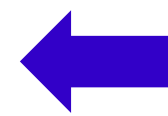

CMP抛光

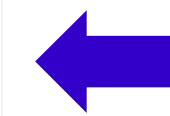

研磨+机械抛光

02工艺介绍

PROCESS INTRODUCTION

单片抛光工艺流程

贴膜-Si/C面减薄 -Si/C面粗抛（单片抛光）-Si面CMP抛光

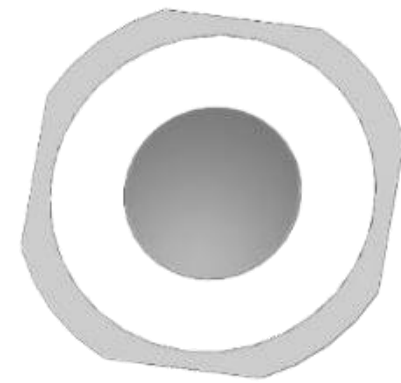

贴膜

贴膜机

辅耗材：UV膜

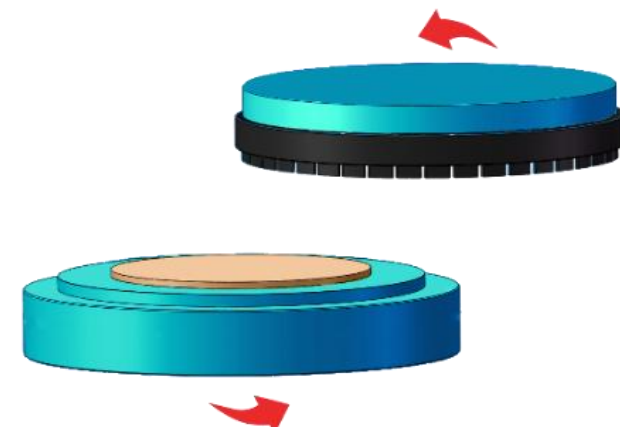

Si/C 面减薄(2步)

半自动单/双轴减薄机
IVG-3020/ IVG-3035
1片/盘（6寸）

辅耗材：
磨盘：金刚石砂轮
粗：去除50um
(去除量可随工艺调整)
精：去除10um
Ra≤5nm

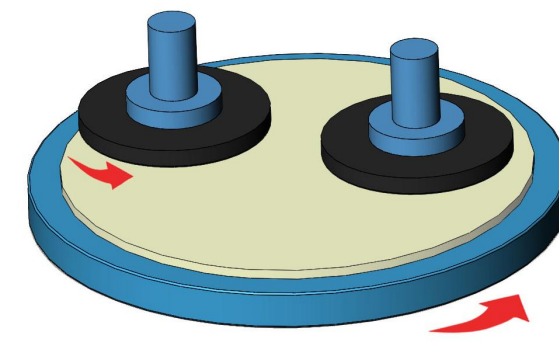

Si/C面CMP粗抛

单片抛光机
TAP-500
2片/盘（6寸）

辅耗材：
抛光垫+氧化铝抛光液
去除2-3um
Ra ≤ 0.2nm

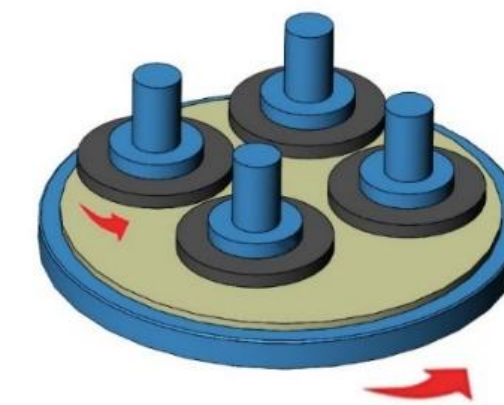

Si面CMP精抛

多片单面抛光机
TSP-1270A
24片/盘（6寸）

辅耗材：
抛光垫+氧化硅抛光液
去除1um
Ra ≤ 0.1nm

优缺点分析：采用单面加工方式，灵活性强；整个加工过程可实现无蜡加工，单片抛光产能稍低，但抛光精度高，可以产出理想的TTV数据

02工艺介绍

PROCESS INTRODUCTION

单片抛光工艺流程



贴膜

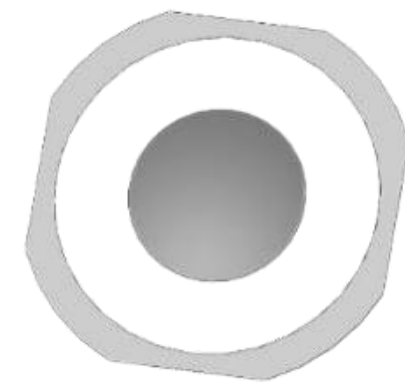
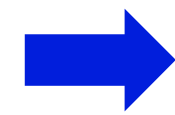

减薄

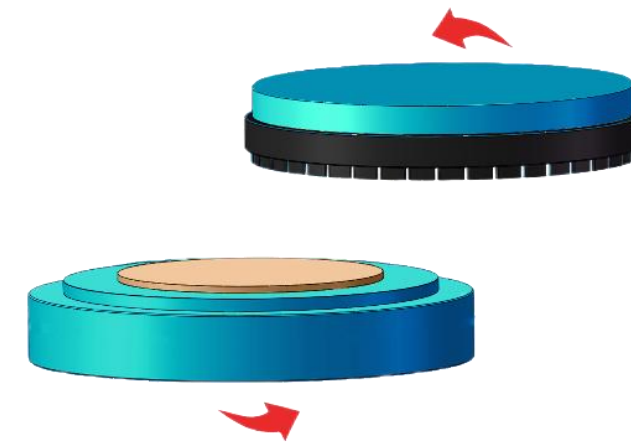
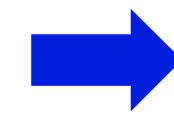

抛光

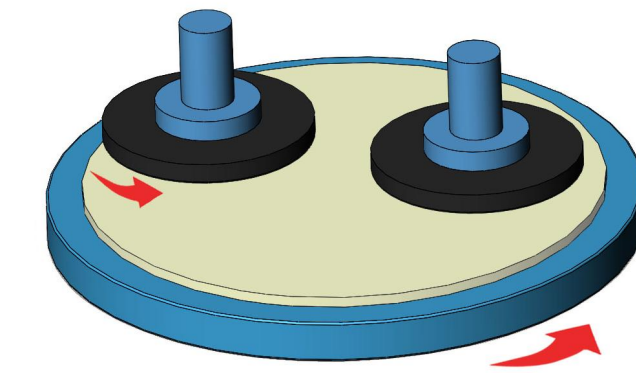
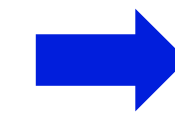

贴膜机



UV照射机



02工艺介绍

PROCESS INTRODUCTION

单片加工工艺路线的优势



02工艺介绍

PROCESS INTRODUCTION

双面抛光工艺流程

双面研磨-双面机械抛光 (DMP) -双面粗抛 (CMP) -Si面CMP精抛



双面研磨

双面研磨机
TDL-1200
12片/盘 (6寸)

辅耗材:
研磨垫+金刚石研磨液
或
铸铁盘+金刚石研磨液

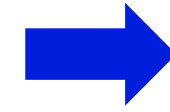

双面DMP抛光

双面抛光机
TDP-1200
12片/盘 (6寸)

辅耗材:
抛光垫+钻石液

精度指标:
 $Ra \leq 2nm$

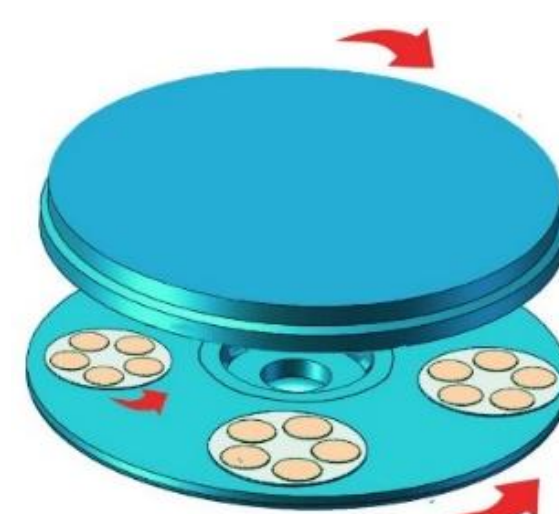

双面CMP粗抛

双面抛光机
TDP-1200A
12片/盘 (6寸)

辅耗材:
抛光垫+氧化铝抛光液

精度指标:
去除6-8um
 $Ra \leq 0.2nm$

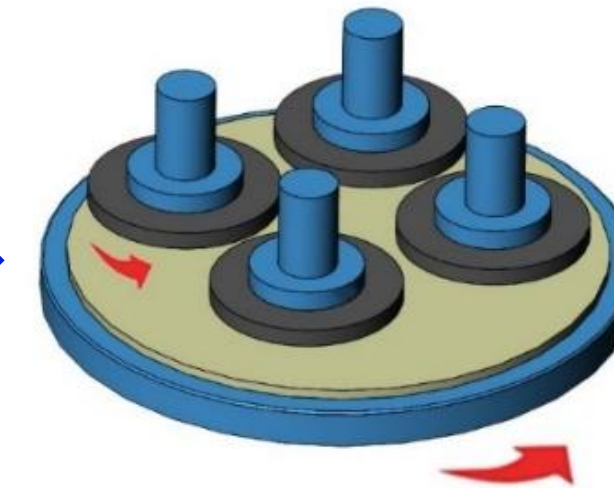

Si面CMP精抛

单面抛光机
TSP-1270A
24片/盘 (6寸)

辅耗材:
抛光垫+氧化硅抛光液

精度指标:
去除 $\leq 1um$
 $Ra \leq 0.1nm$

优缺点分析: 当前国内主流工艺路线, 粗抛采用双面抛光工艺, 面型精度好, 但C面和Si的去除量不一致。

02 工艺介绍

PROCESS INTRODUCTION

双面抛光工艺流程



双面研磨



双面DMP抛光

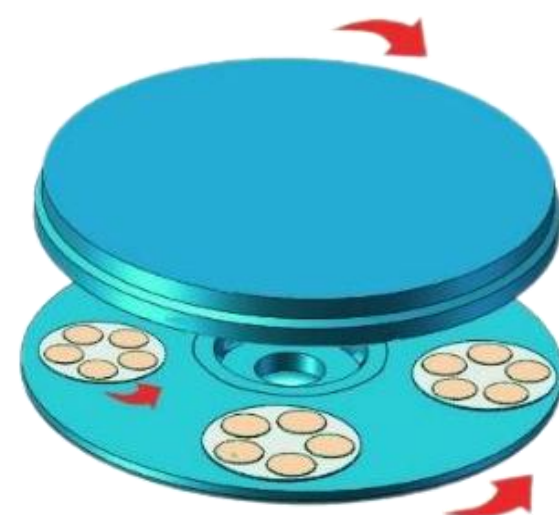

双面CMP抛光

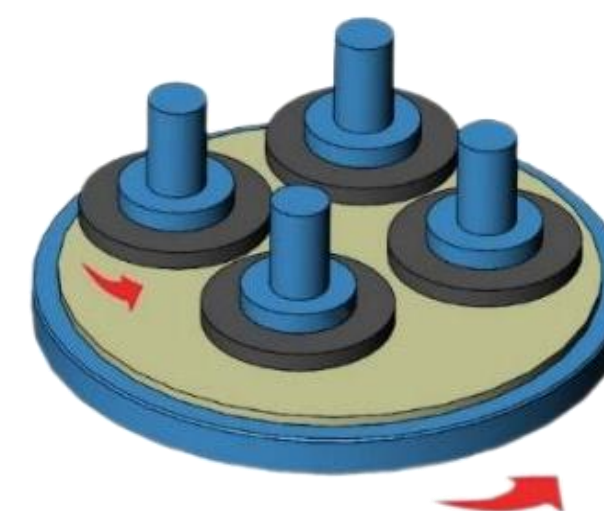

单面CMP精抛



02工艺介绍

PROCESS INTRODUCTION

减薄&多片抛光工艺流程

双面研磨 (可选) - Si/C面减薄 - 双面粗抛 - Si面CMP抛光



双面研磨

双面研磨机
TDL-1200
12片/盘 (6寸)

辅耗材:
磨盘: 铸铁盘磨料:
单晶金刚石研磨液
双面去除15um
(去除量可随工艺调整)

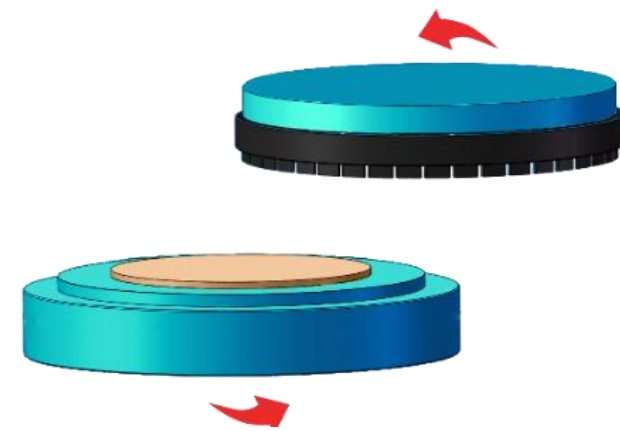

Si/C 面减薄(2步)

全自动减薄机
TFG-3200 (6寸)

辅耗材:
磨盘: 金刚石砂轮
粗: 单面去除50um
(去除量可随工艺调整)
精: 单面去除10um
Ra≤5nm



双面CMP粗抛

双面抛光机
TDP-1200A
12片/盘 (6寸)

辅耗材:
抛光垫+氧化铝抛光液

精度指标:
去除6-8um
Ra ≤ 0.2nm

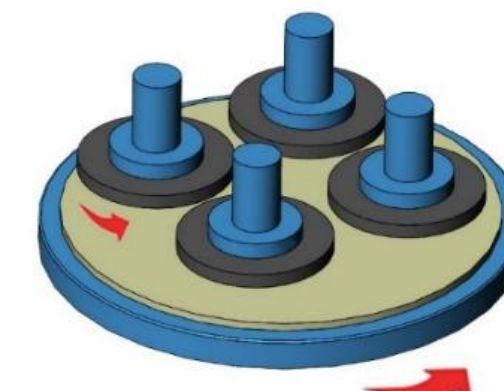

Si面CMP精抛

多片单面抛光机
TSP-1270A
24片/盘 (6寸)

辅耗材:
抛光垫+氧化硅抛光液
去除1um
Ra ≤ 0.1nm

优缺点分析: 减薄工序可实现全自动作业, 但精磨砂轮的成本较高。

02 工艺介绍

PROCESS INTRODUCTION

减薄&多片抛光工艺流程



双面研磨 (可选)



双面抛光机

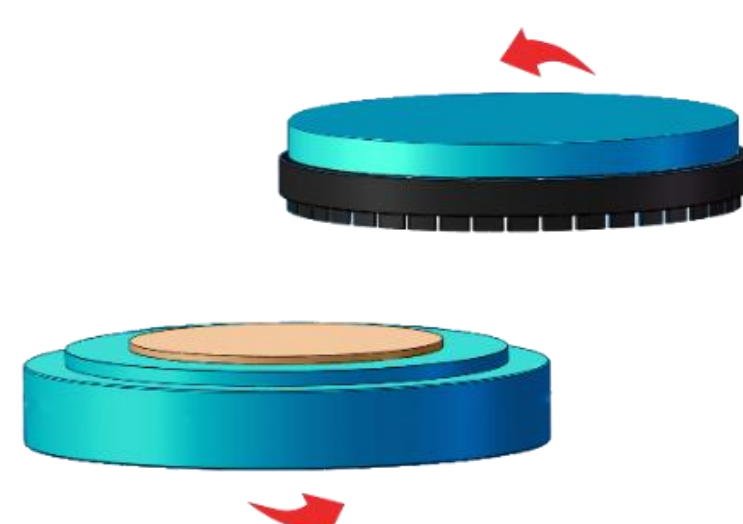
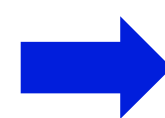

Si/C 面减薄(2步)



全自动减薄机

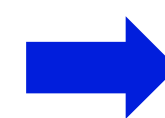

双面CMP粗抛



双面抛光机



单面CMP精抛



单面抛光机

03 PART THREE

碳化硅衬底 设备介绍

EQUIPMENT INTRODUCTION



03设备介绍

EQUIPMENT INTRODUCTION

单片加工工艺主要加工设备—减薄机

作业方式: 由机械手将晶圆放在减薄机的多孔真空陶瓷吸盘上,即可全自动减薄作业,机台配置IPG自动厚度测量和补偿系统,可自动减薄至目标值才停止

砂轮轴: 2个

工件轴数量: 3个

最大晶片规格: 8英寸

晶圆固定方式: 真空吸附/IPG接触测量



全自动减薄机 TFG-3200

03设备介绍

EQUIPMENT INTRODUCTION

全自动减薄机

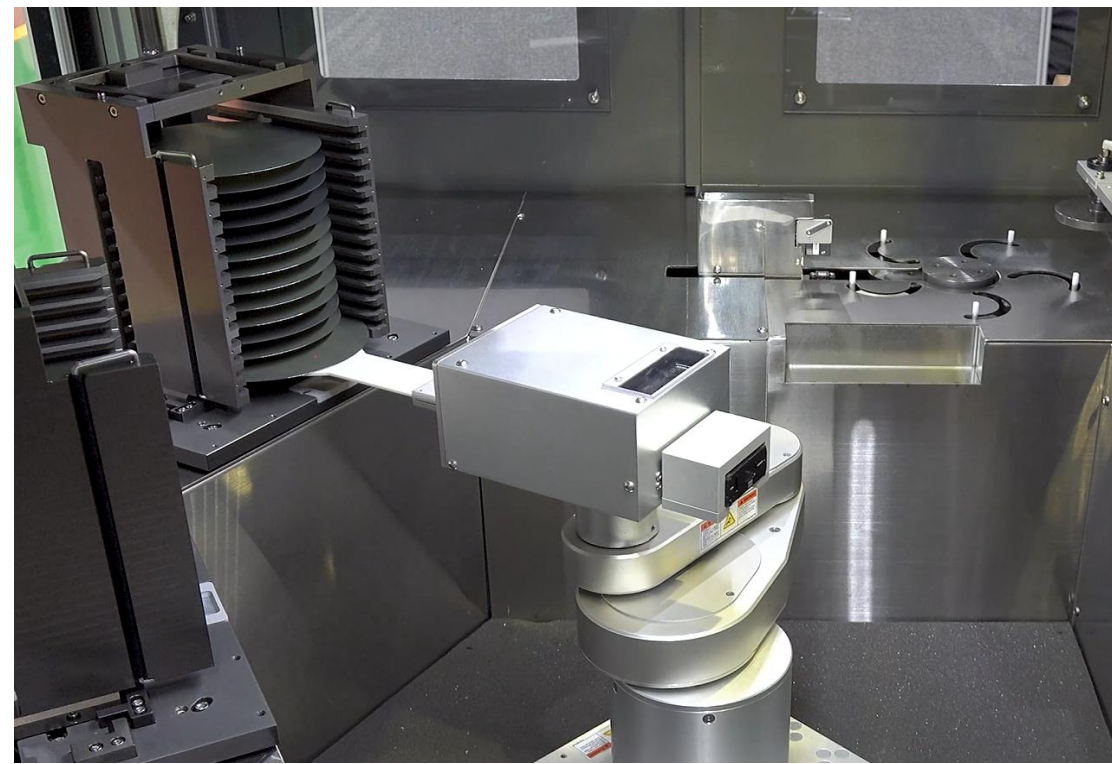

进料盒取片

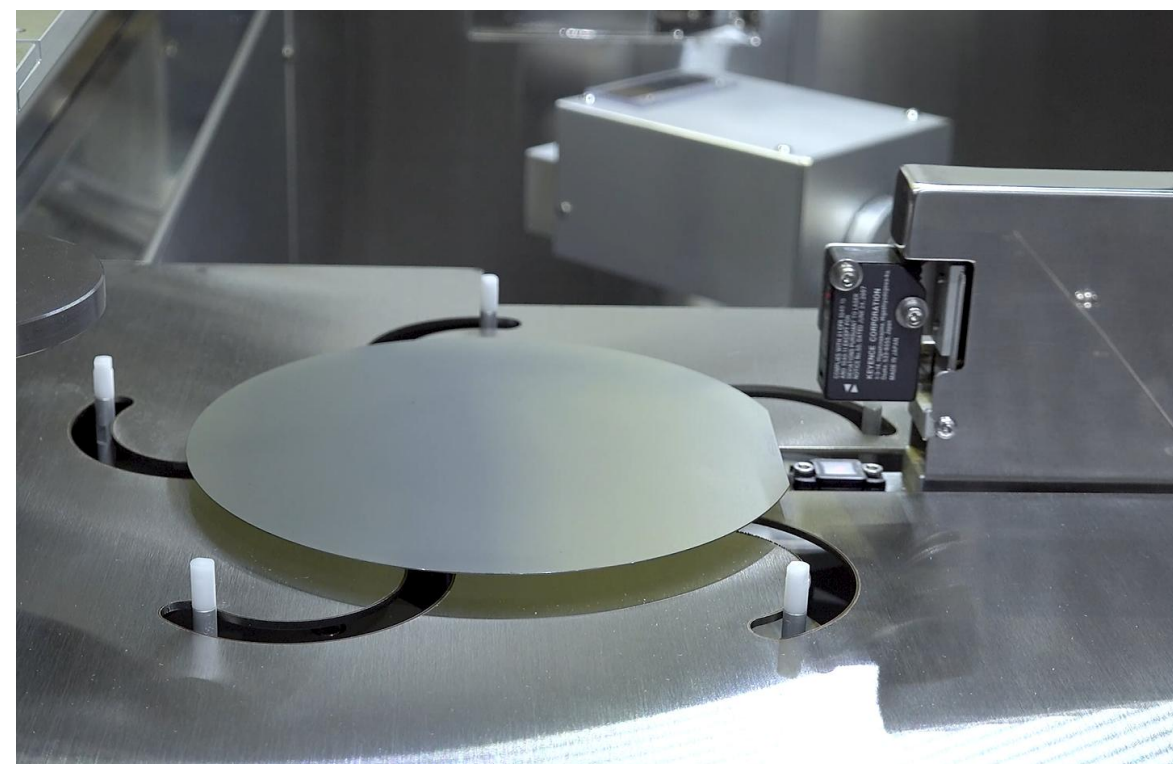

对心定位

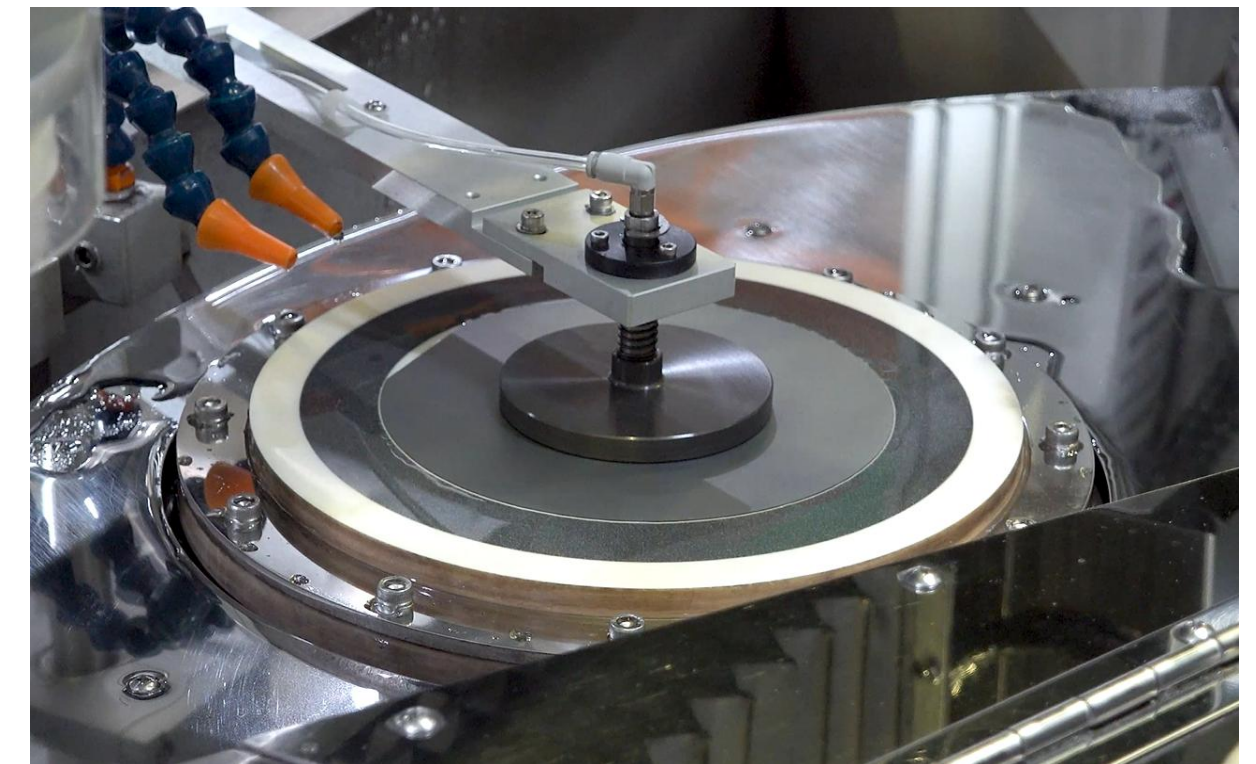

搬运至减薄工位减薄

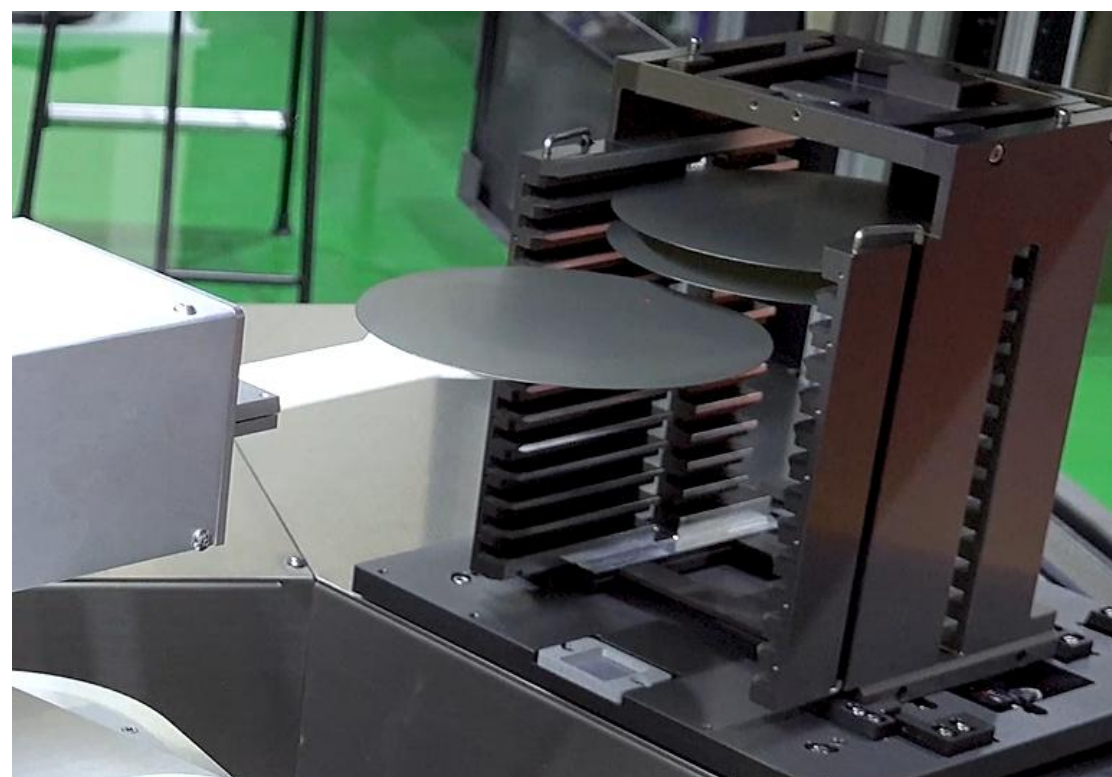

搬运至出料盒



清洗甩干

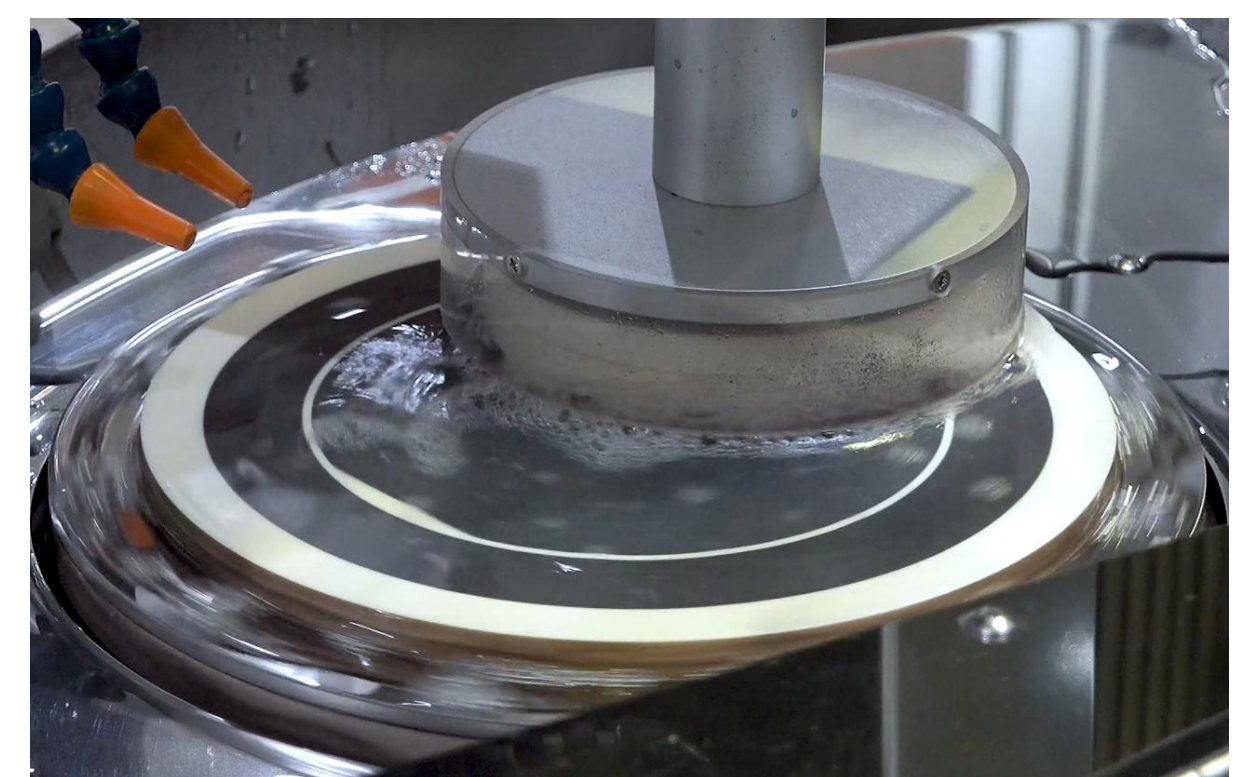

清洗工作台

03设备介绍

EQUIPMENT INTRODUCTION

碳化硅晶圆研磨案例：8寸N型SiC晶圆

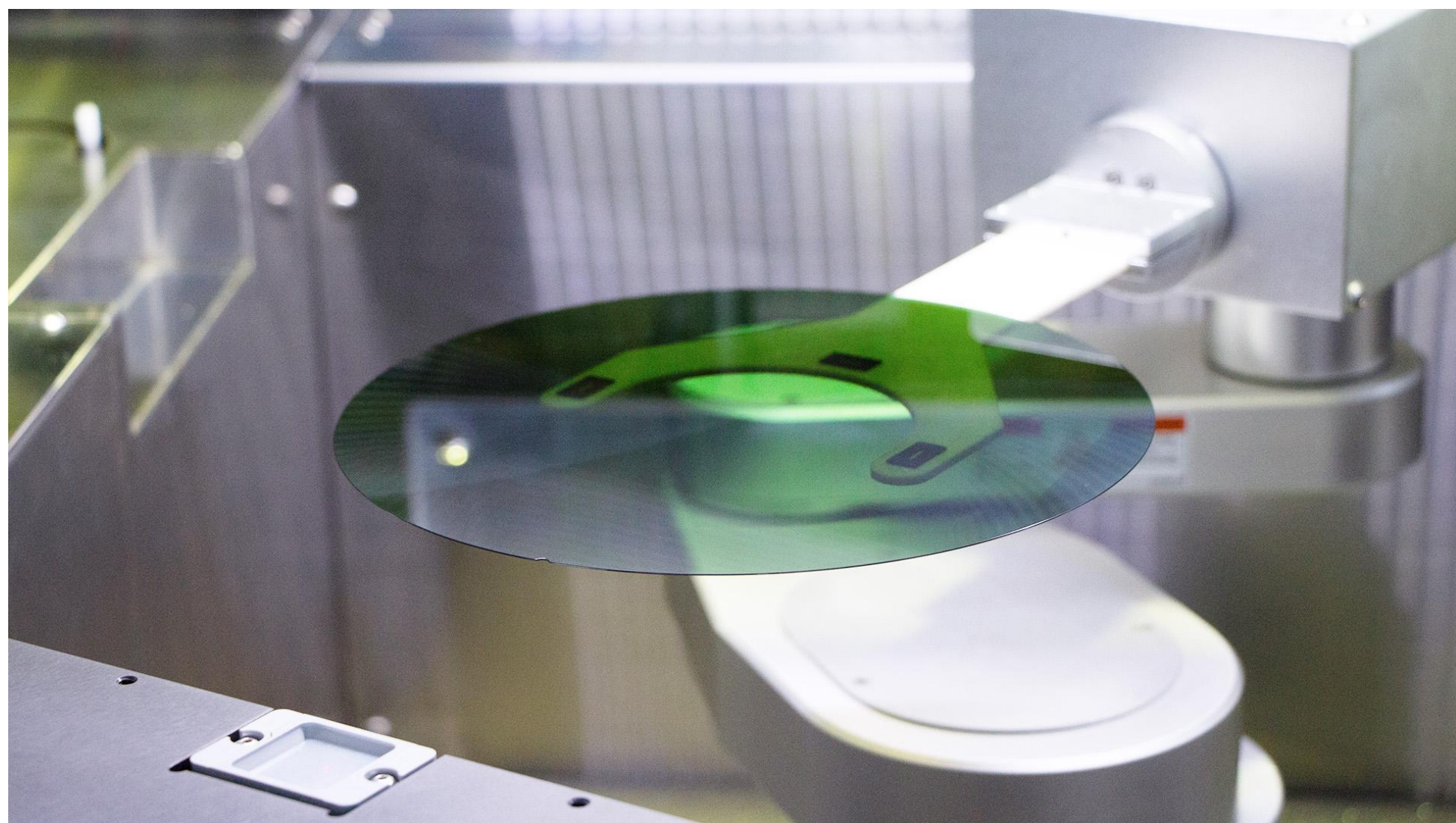

研削（8英寸碳化硅晶圆）

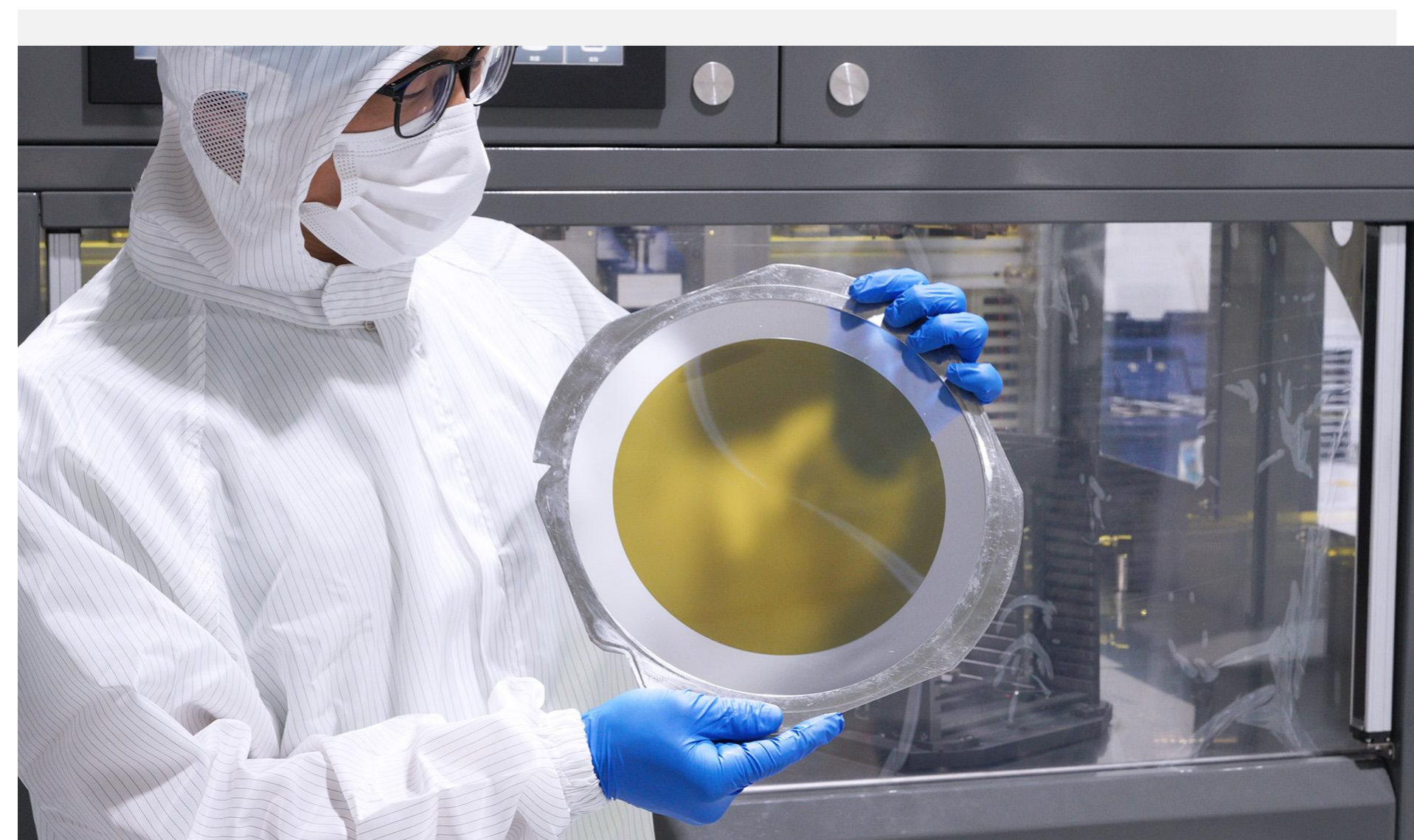

8英寸SiC晶圆

03设备介绍

EQUIPMENT INTRODUCTION

碳化硅晶锭研磨案例：6寸N型SiC晶锭

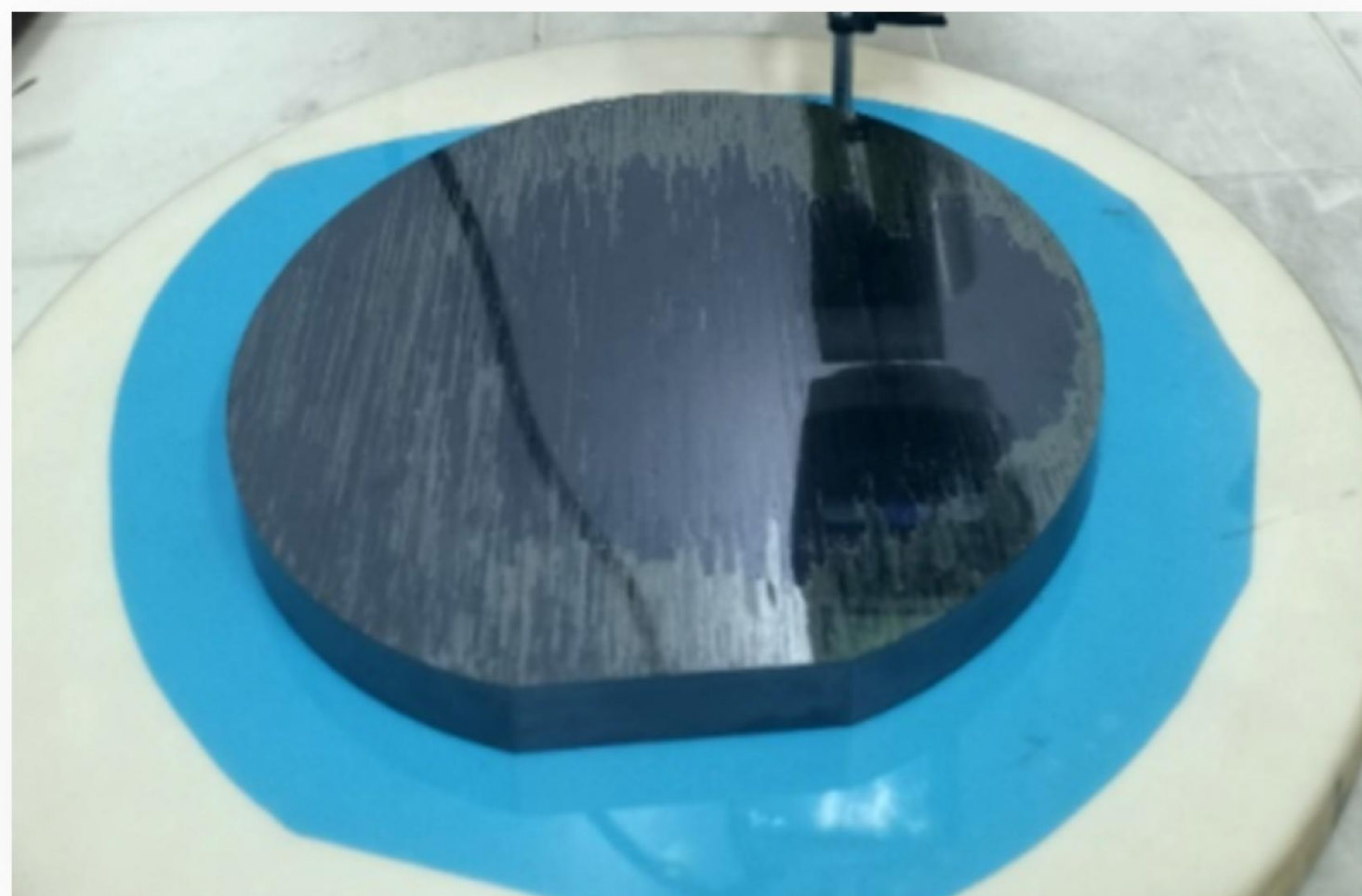

晶锭-激光剥离后

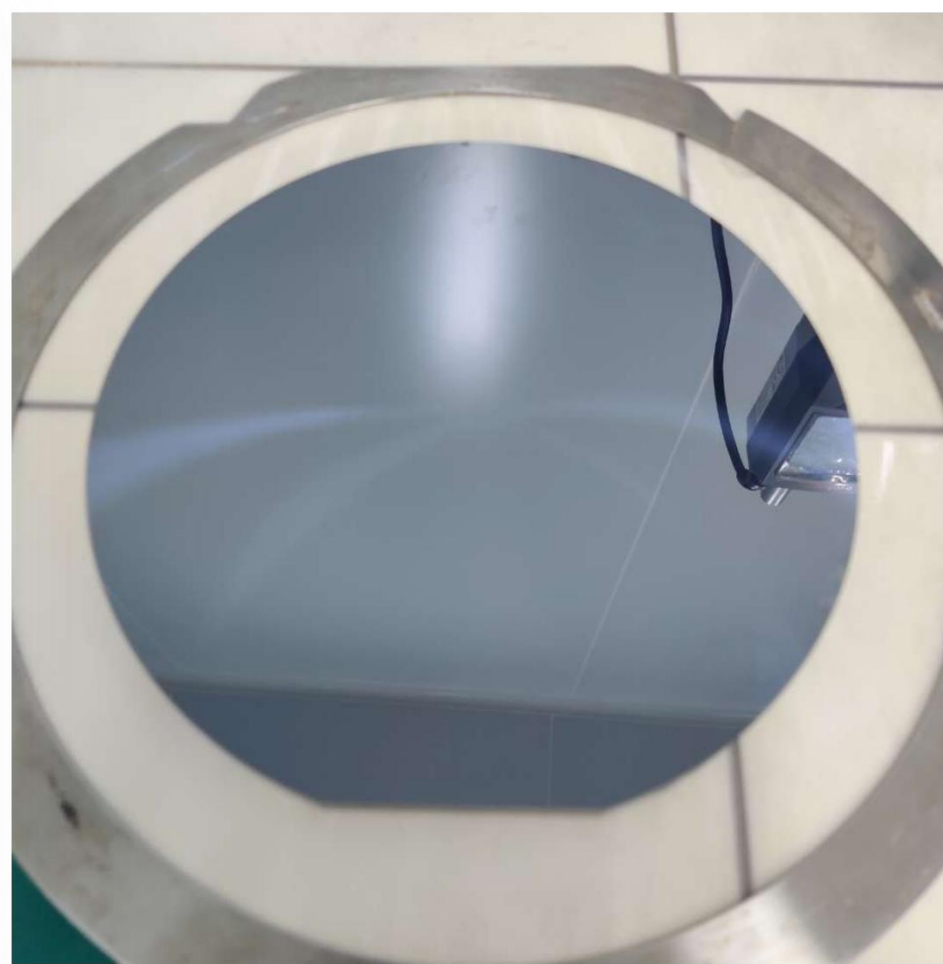

粗磨后

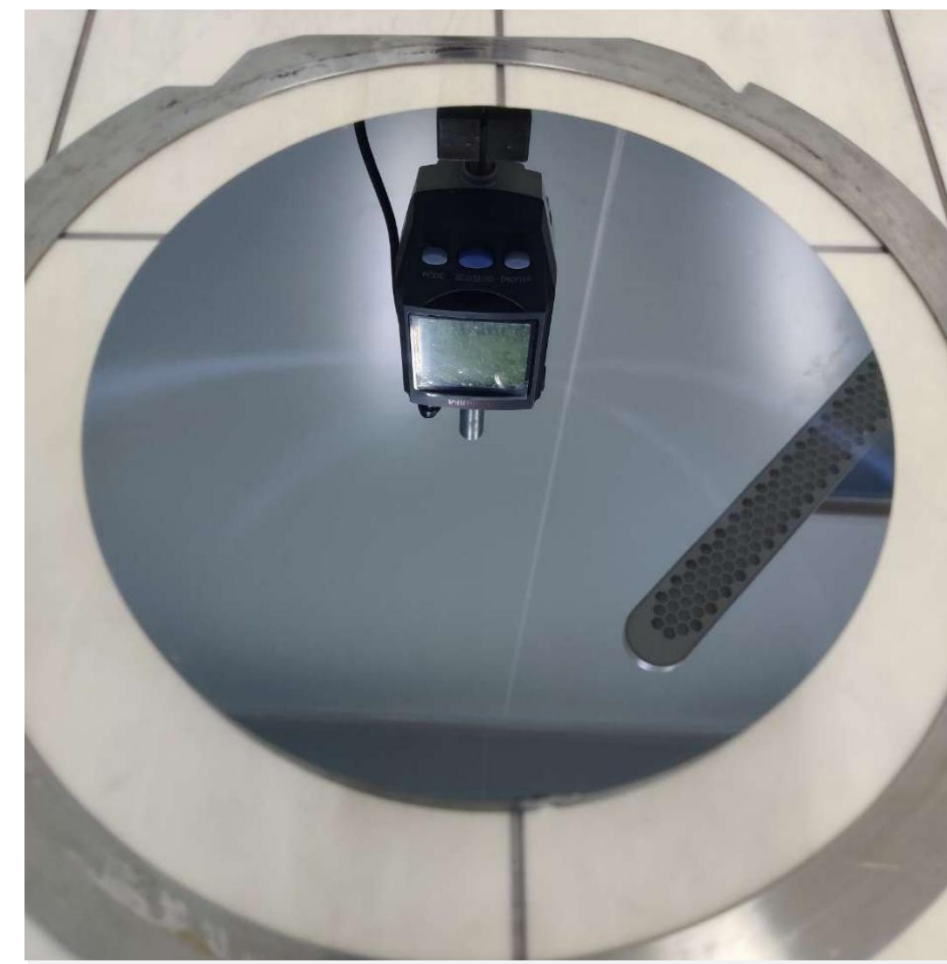

精磨后

03设备介绍

EQUIPMENT INTRODUCTION

测量方式介绍

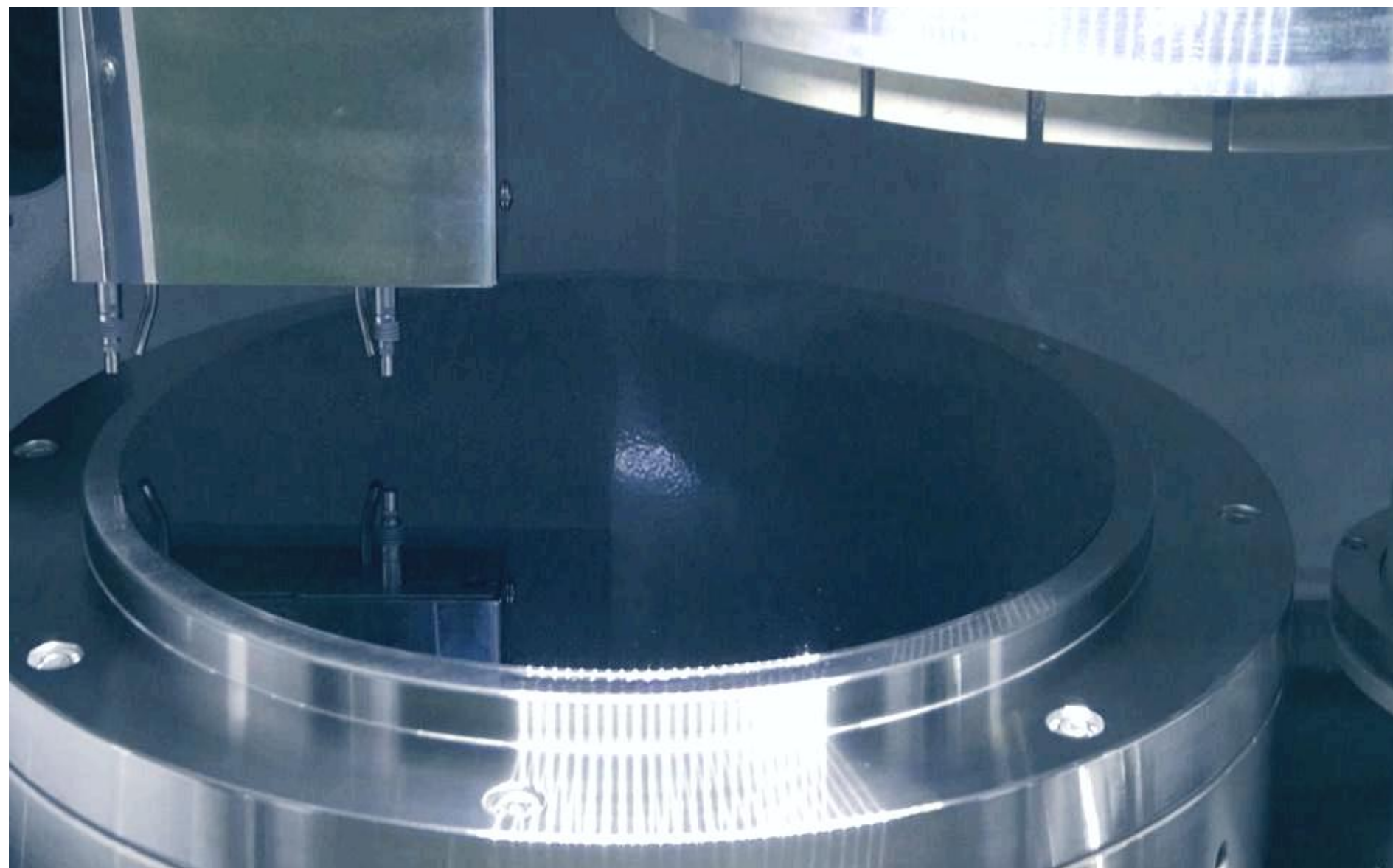

接触式测量方式

- 3段加工程序，4次测量过程，测量时间长

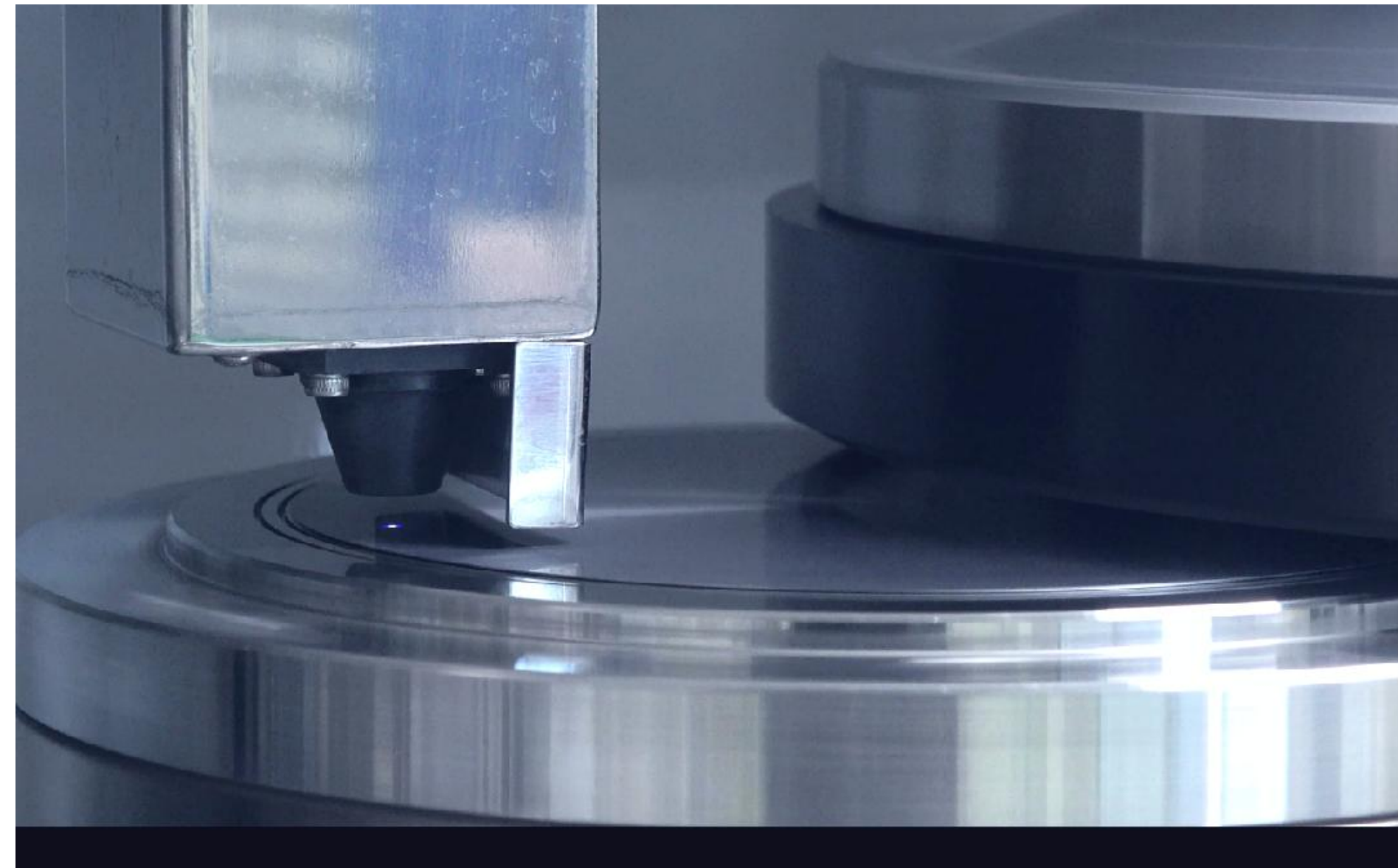

非接触式测量方式

- 加工过程中实时监测厚度，无测量等待时间
- 非接触测量，不会造成晶片表面损伤

03设备介绍

EQUIPMENT INTRODUCTION

减薄机

型号: IVG-3035 (双轴)

晶片尺寸: 6-8寸

工艺指标

6寸SiC衬底 TV5: $\leq 2\mu\text{m}$

厚度偏差: $\pm 2\mu\text{m}$

去除速率: $0.2-0.5\mu\text{m}/\text{sec}$

适用范围

加工精度

03设备介绍

EQUIPMENT INTRODUCTION

单片加工工艺主要加工设备—单片抛光机



单片抛光机 TAP-500

01 抛光头驱动系统

抛光头具有自转和往复运动驱动系统，保证抛光精度

02 抛光头真空吸附

抛光头采用真空吸附方式，无需贴蜡，上下片操作简便

03 抛光精度高

抛光头采用气囊背压方式，压力均匀，抛光精度高

04 抛光效率高

单片抛光，高压抛光，效率更高

03设备介绍

EQUIPMENT INTRODUCTION

单片加工工艺主要加工设备—单片抛光机

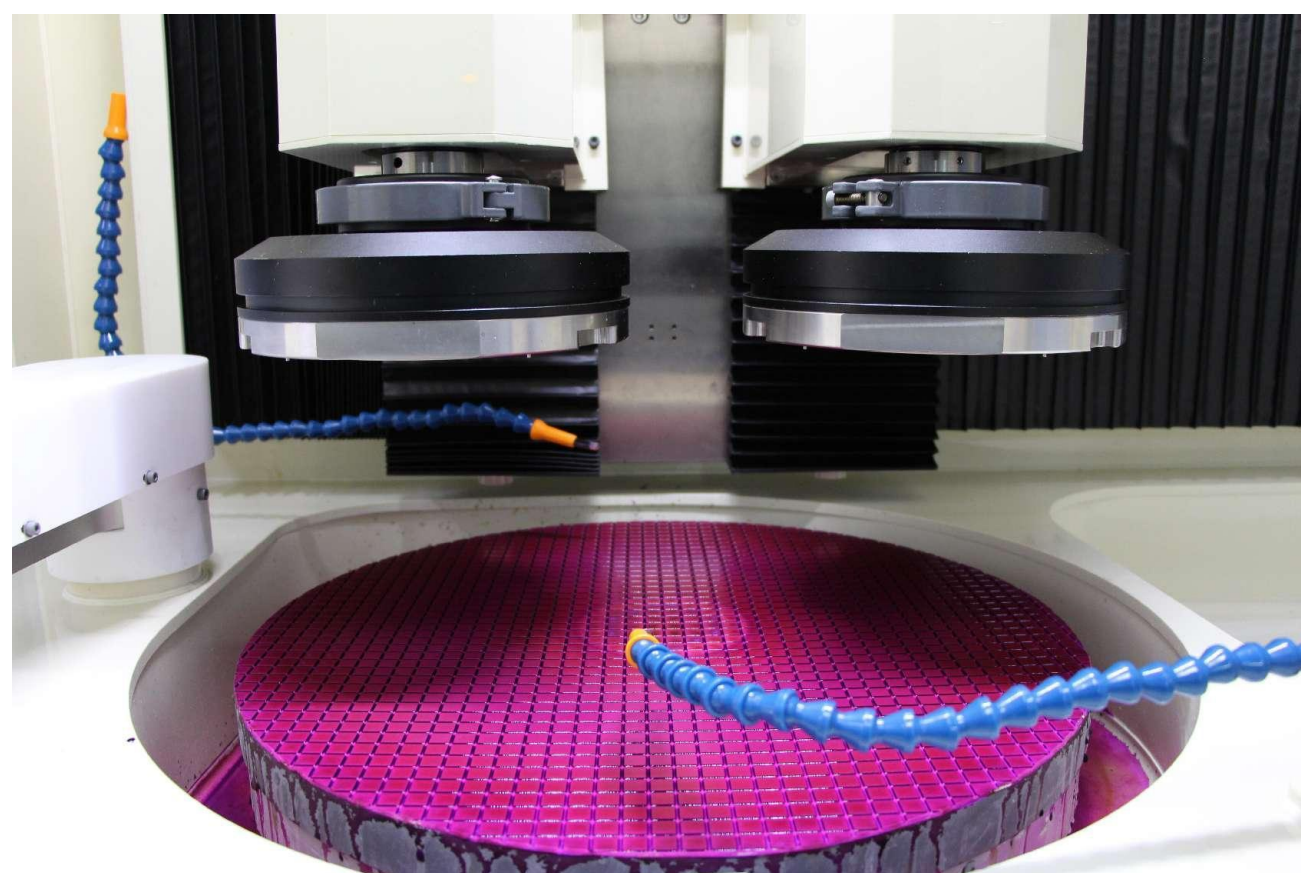
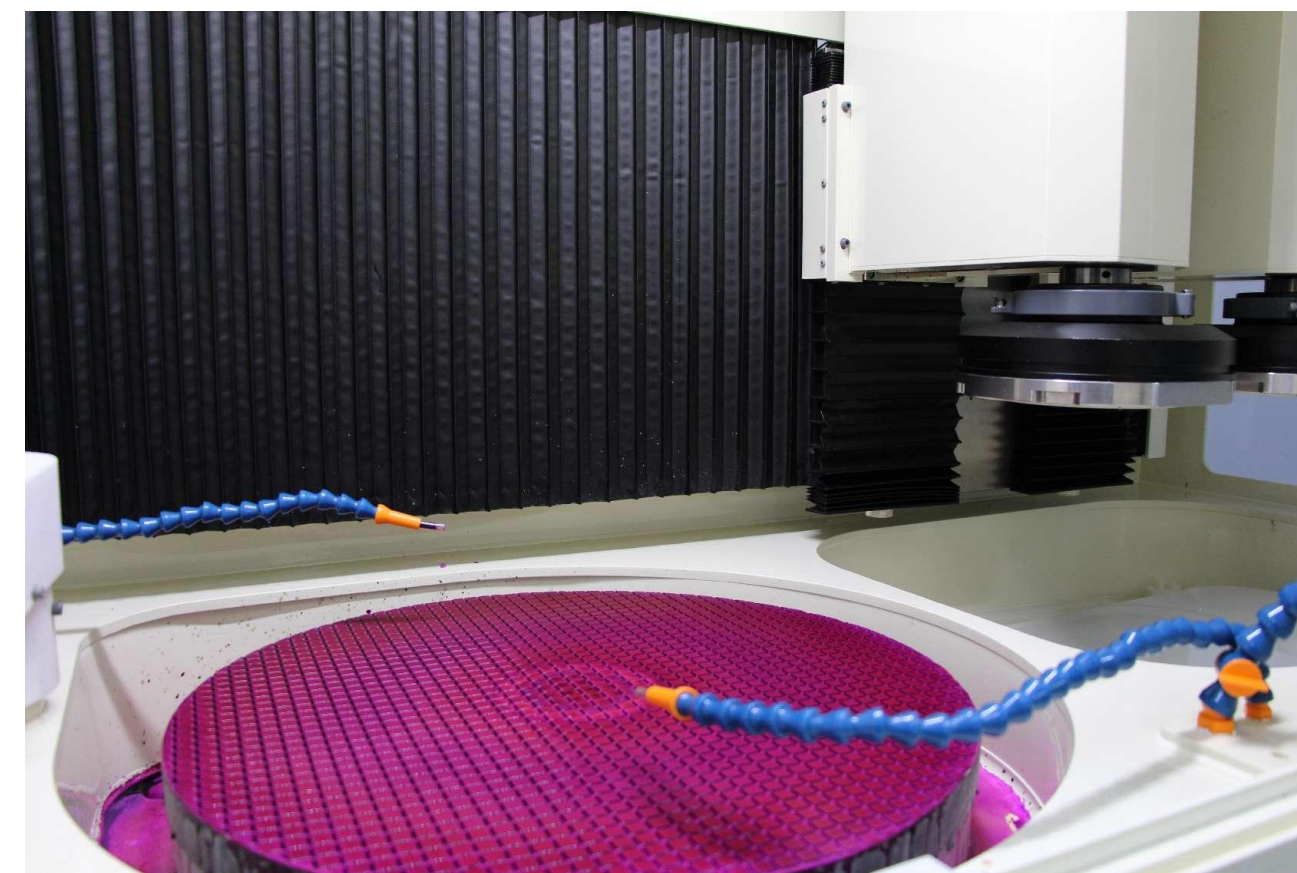
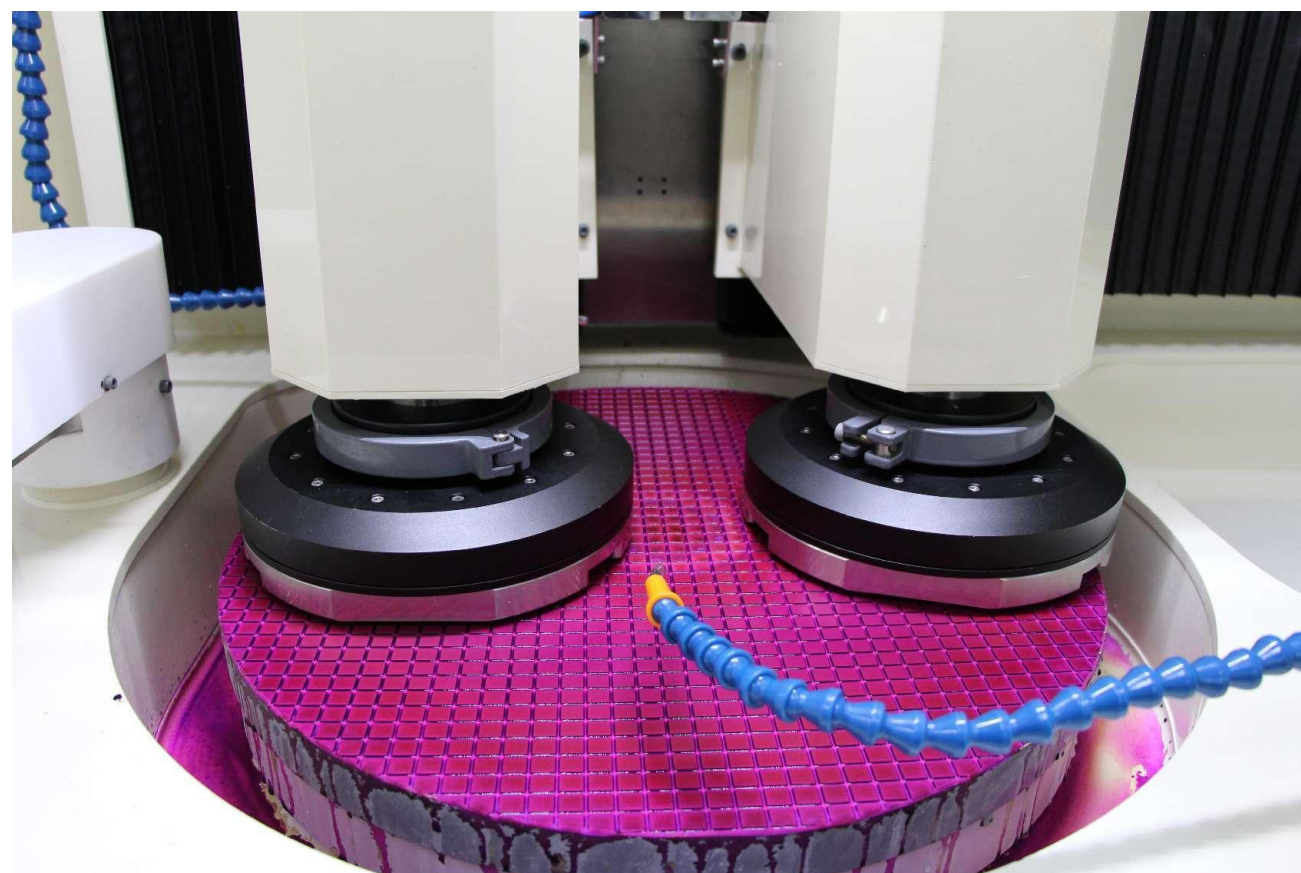

03设备介绍

EQUIPMENT INTRODUCTION

单片抛光机

型 号: TAP-500 (双轴) TAP-600 (双轴)

适用尺寸: 6寸 8寸

适用范围

加工精度

工艺指标

6寸SiC衬底

TTV: $\leq 2\mu\text{m}$ 保持前工序TV5精度

厚度偏差: $\pm 2\mu\text{m}$

03设备介绍

EQUIPMENT INTRODUCTION

双面抛光机



双面抛光机 TDP-1200

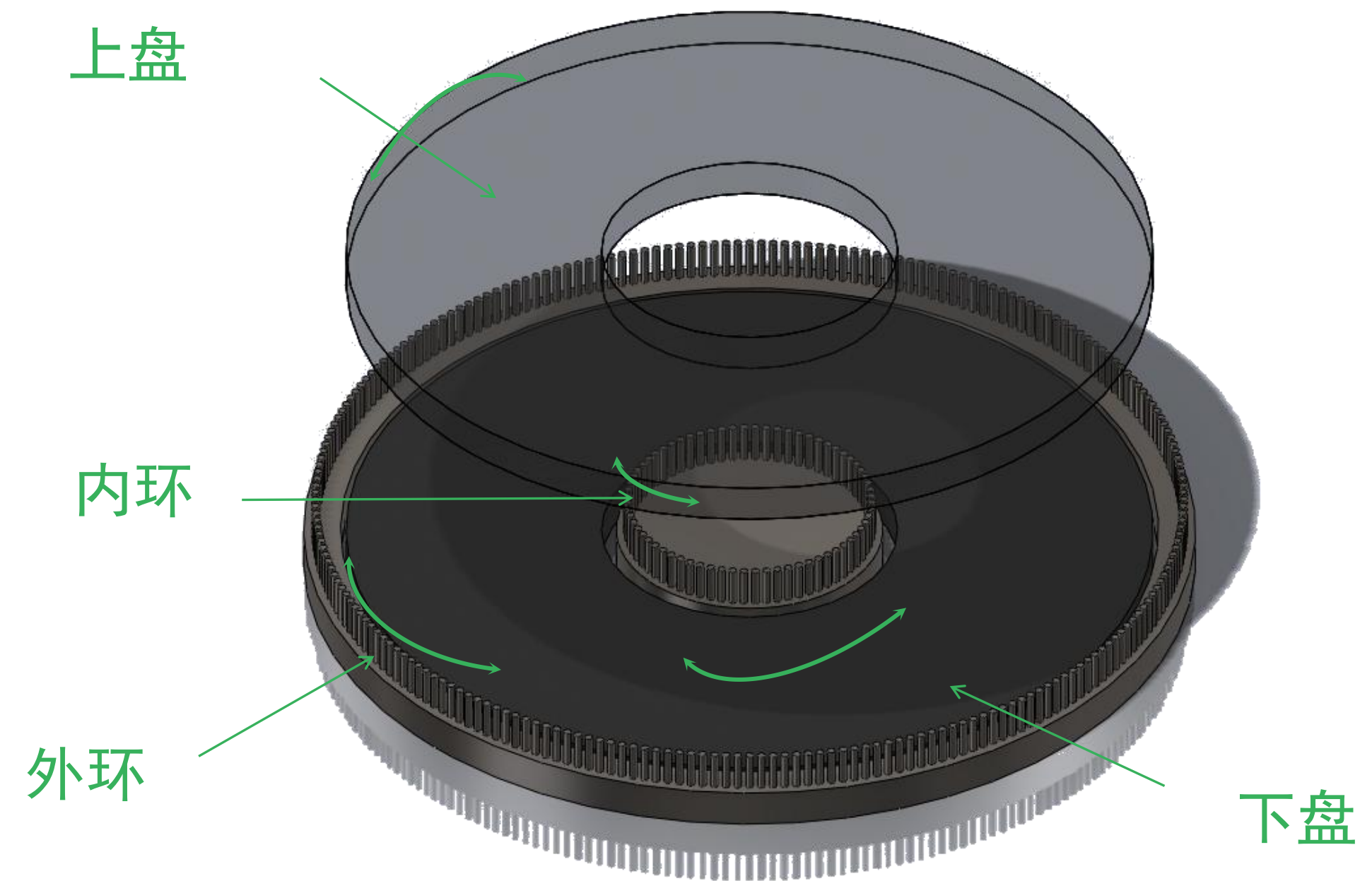

4电机4way驱动

03设备介绍

EQUIPMENT INTRODUCTION

双面抛光机



双面抛光机 TDP-1200

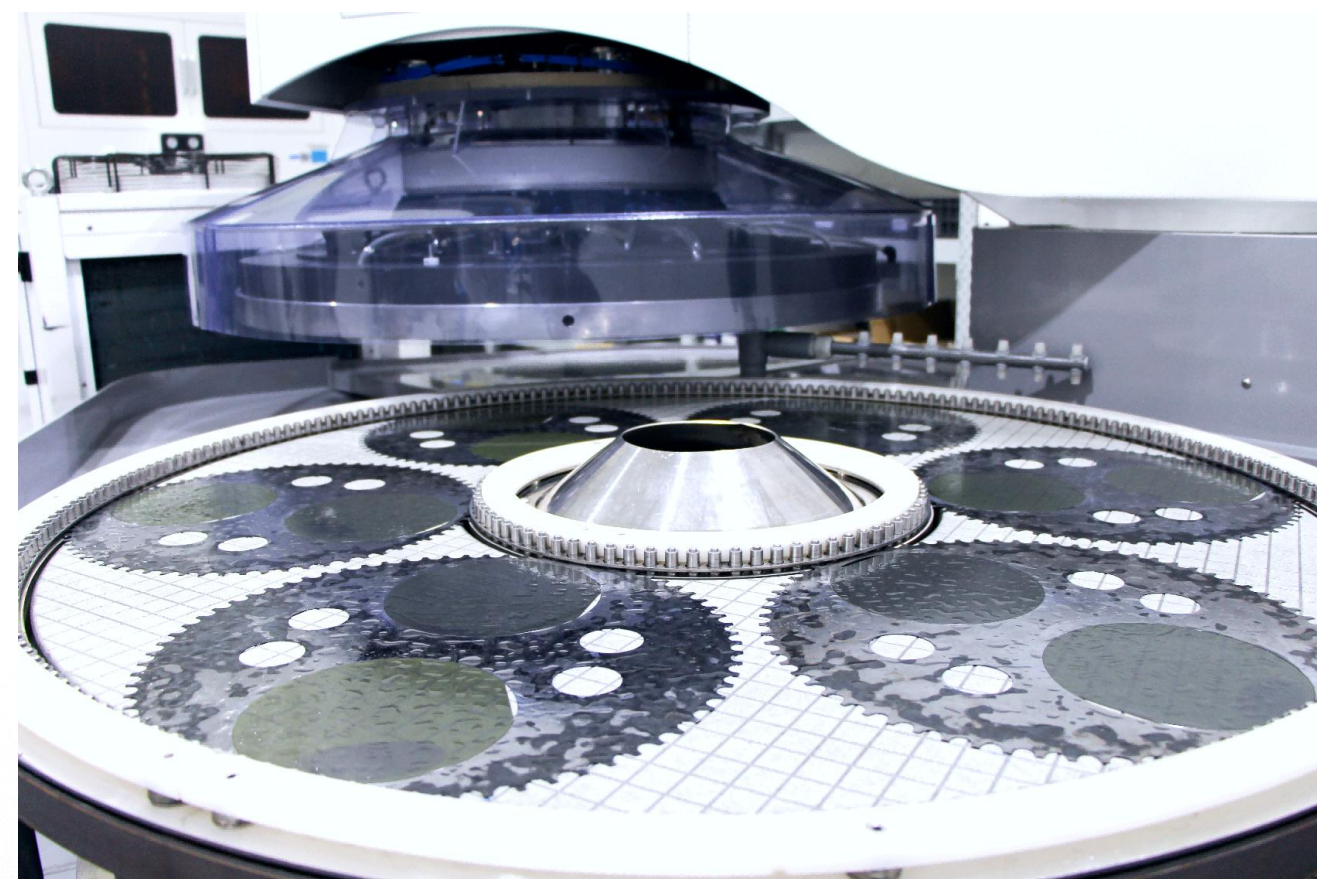

03设备介绍

EQUIPMENT INTRODUCTION

双面抛光机

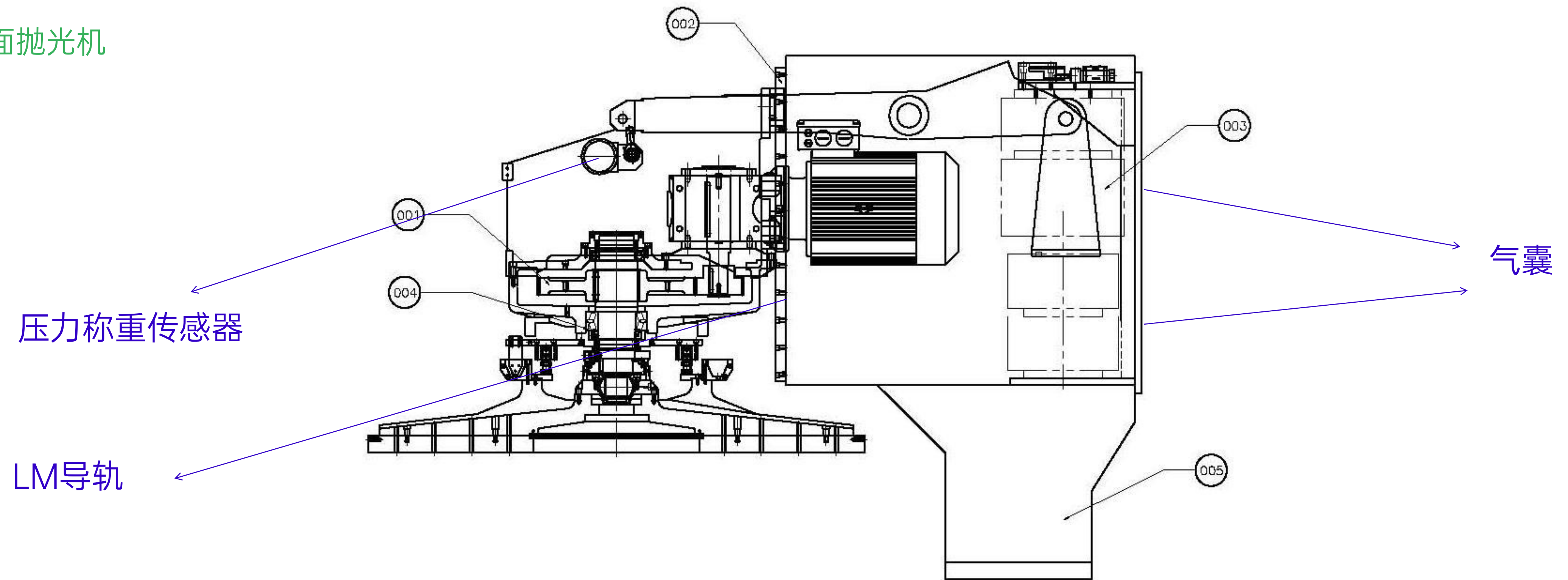

01.上盘上下方式 - 采用4组排列的LM 导轨，可以承受到更大的压力，刚性更好

02.加压方式- 采用气囊加压方式，比例阀精确控制压力

03.配置压力称重传感器

03设备介绍

EQUIPMENT INTRODUCTION

SiC衬底双抛工艺DMP后精度数据

项目	厚度	TTV	LTV	Bow	Warp	Ra
数据	364um	1.5um	0.6um	7.0um	20um	< 3nm

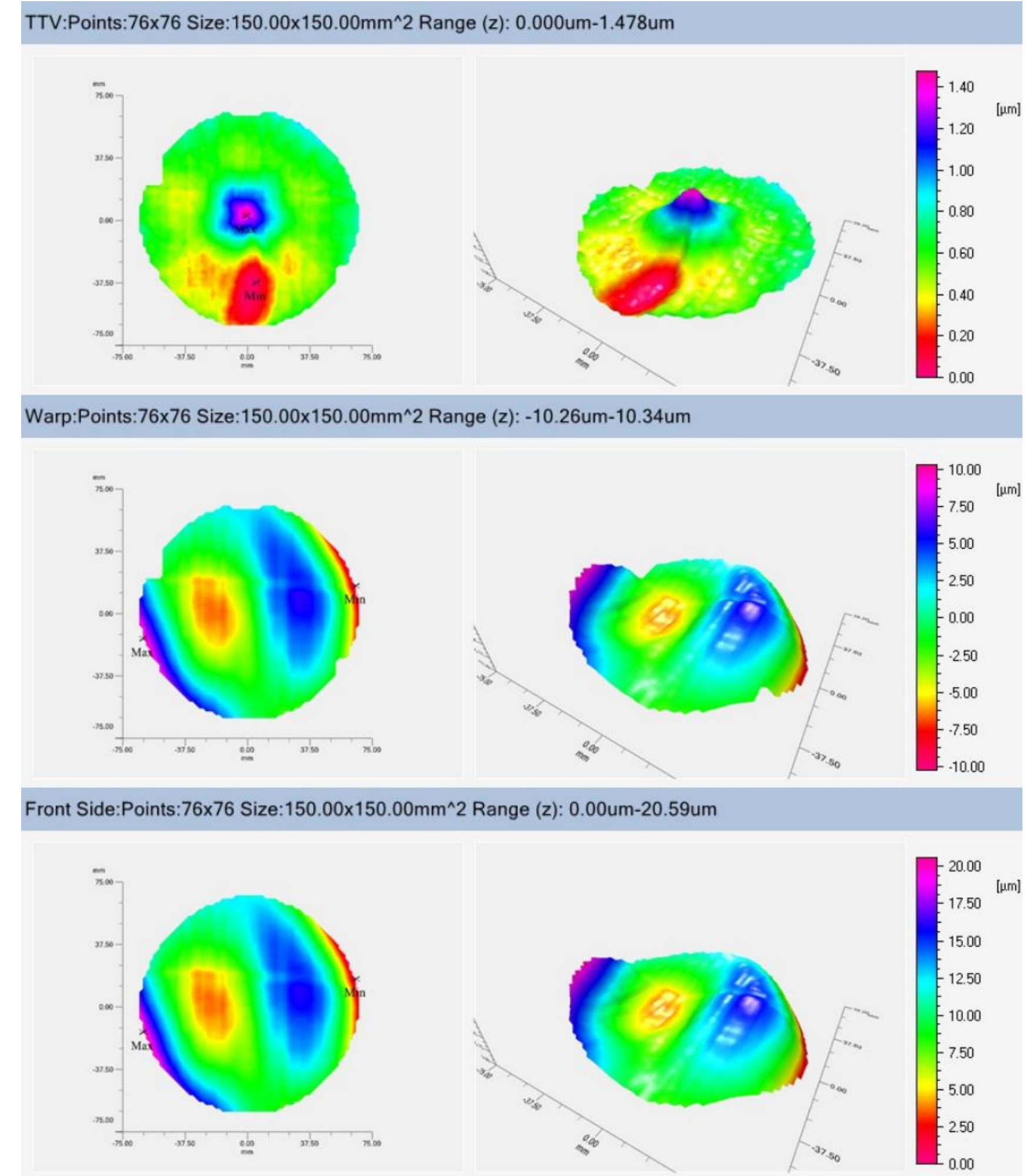
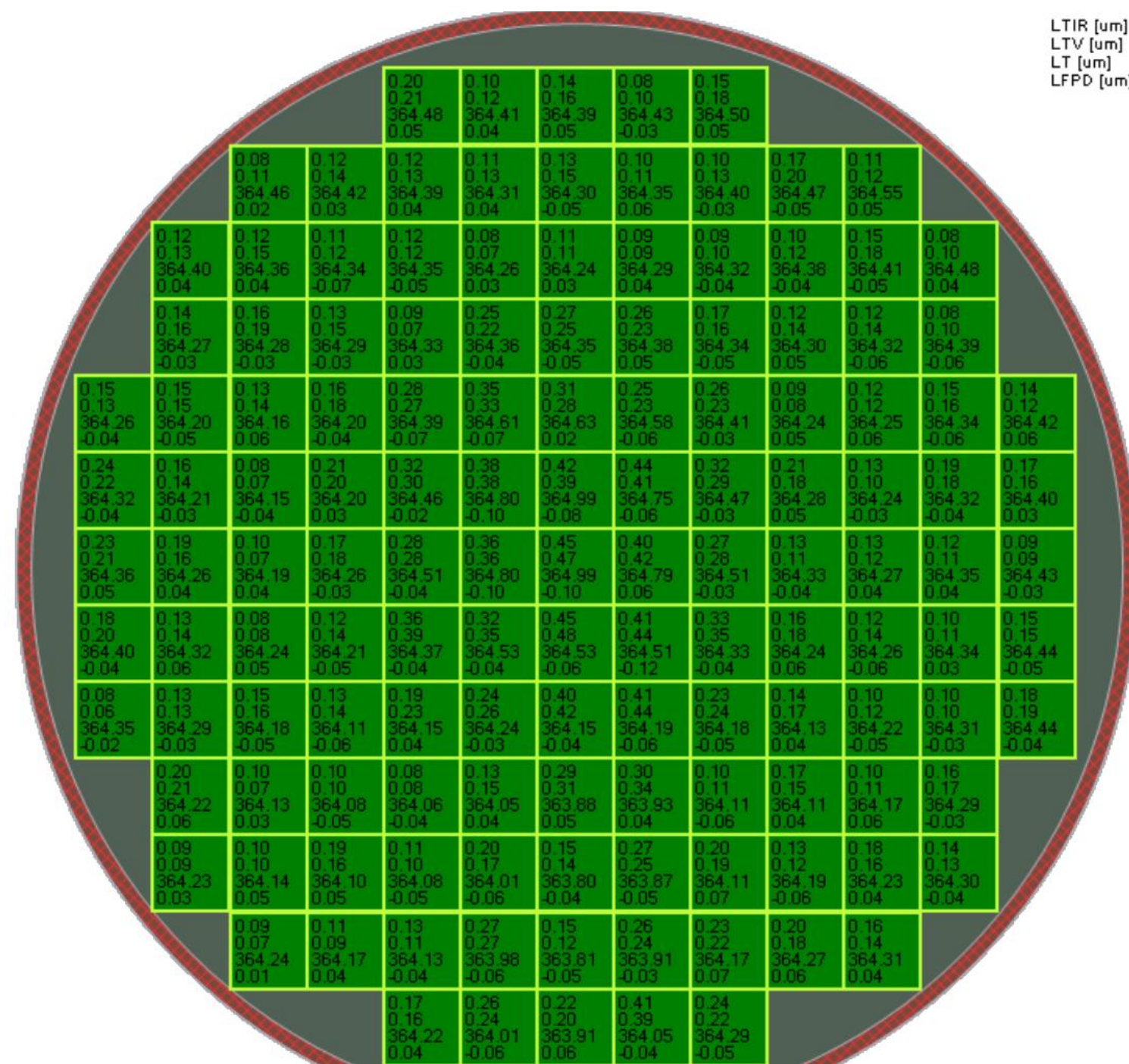

03设备介绍

EQUIPMENT INTRODUCTION

SiC衬底双抛工艺CMP后精度数据

项目	厚度	TTV	LTV	Bow	Warp	Ra
数据	356um	1.2um	0.5um	5um	10um	0.1nm

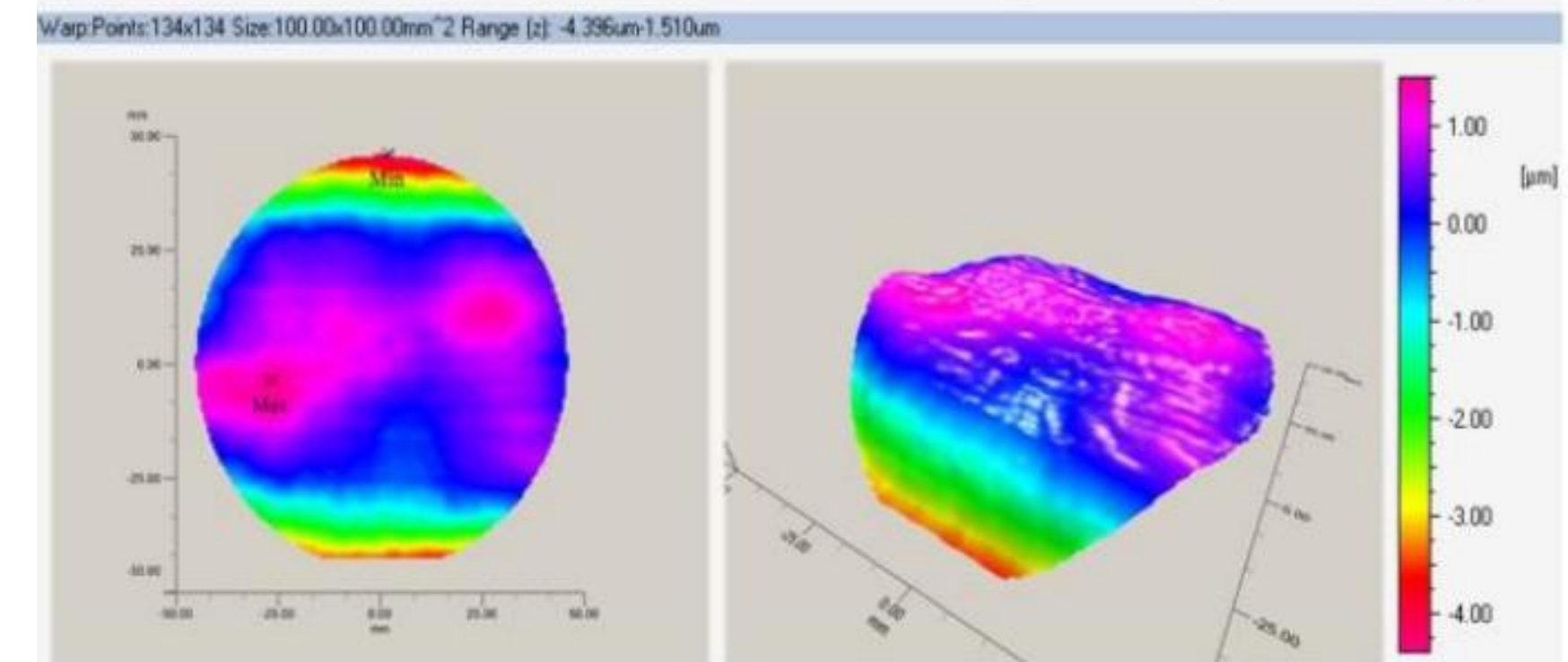
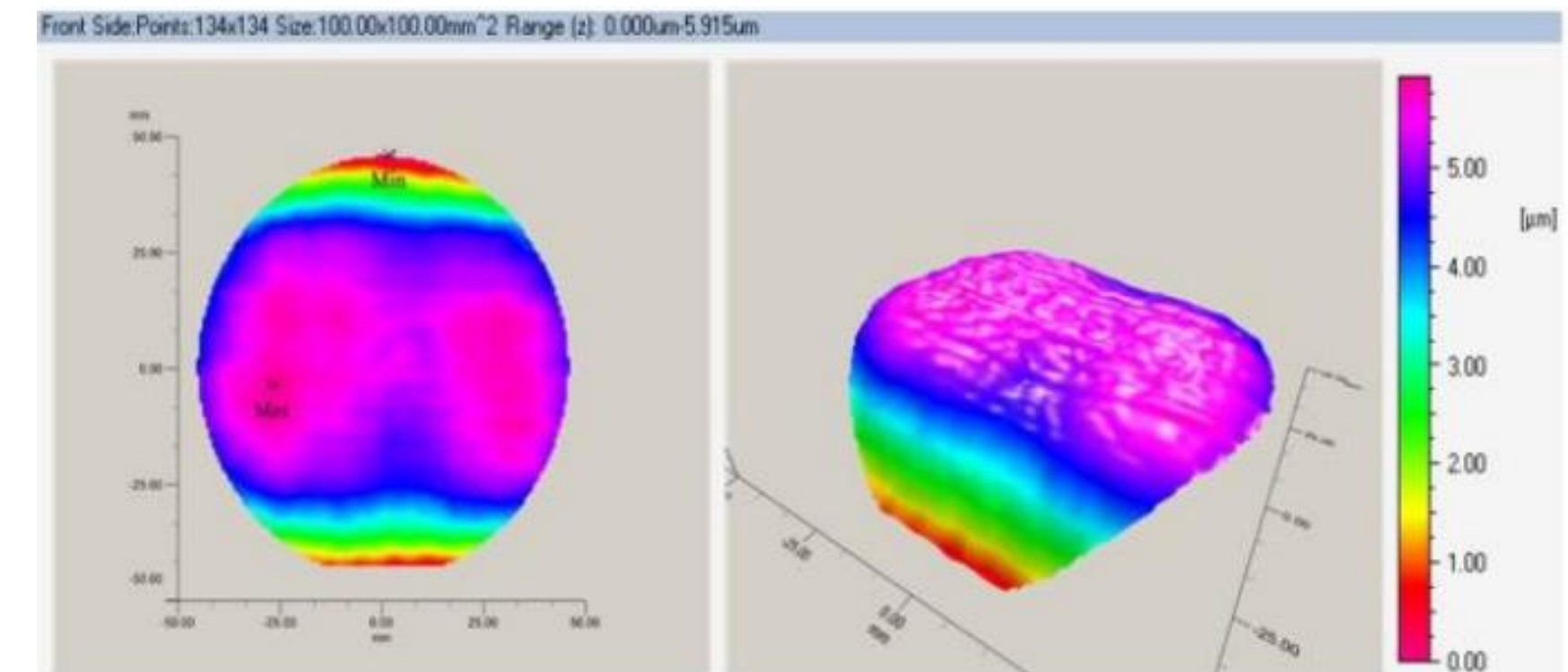
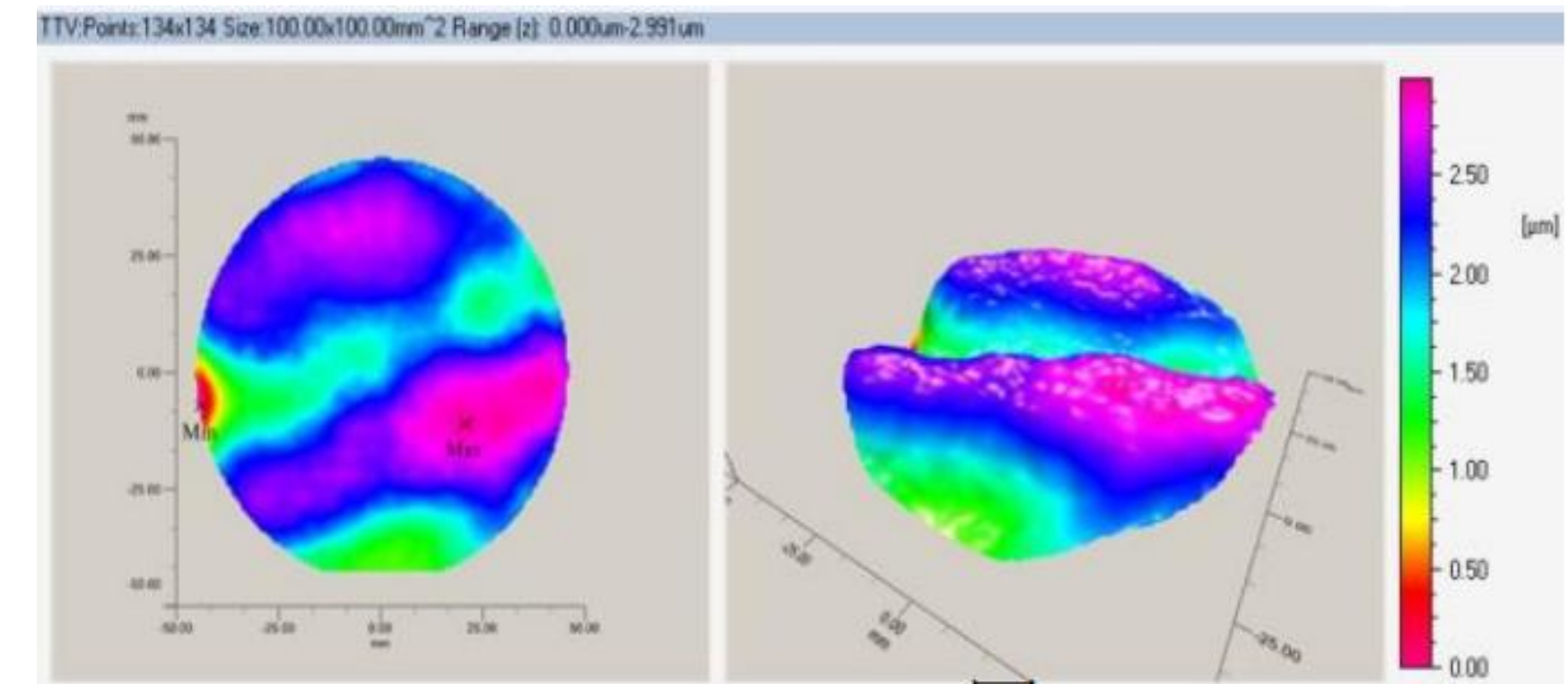
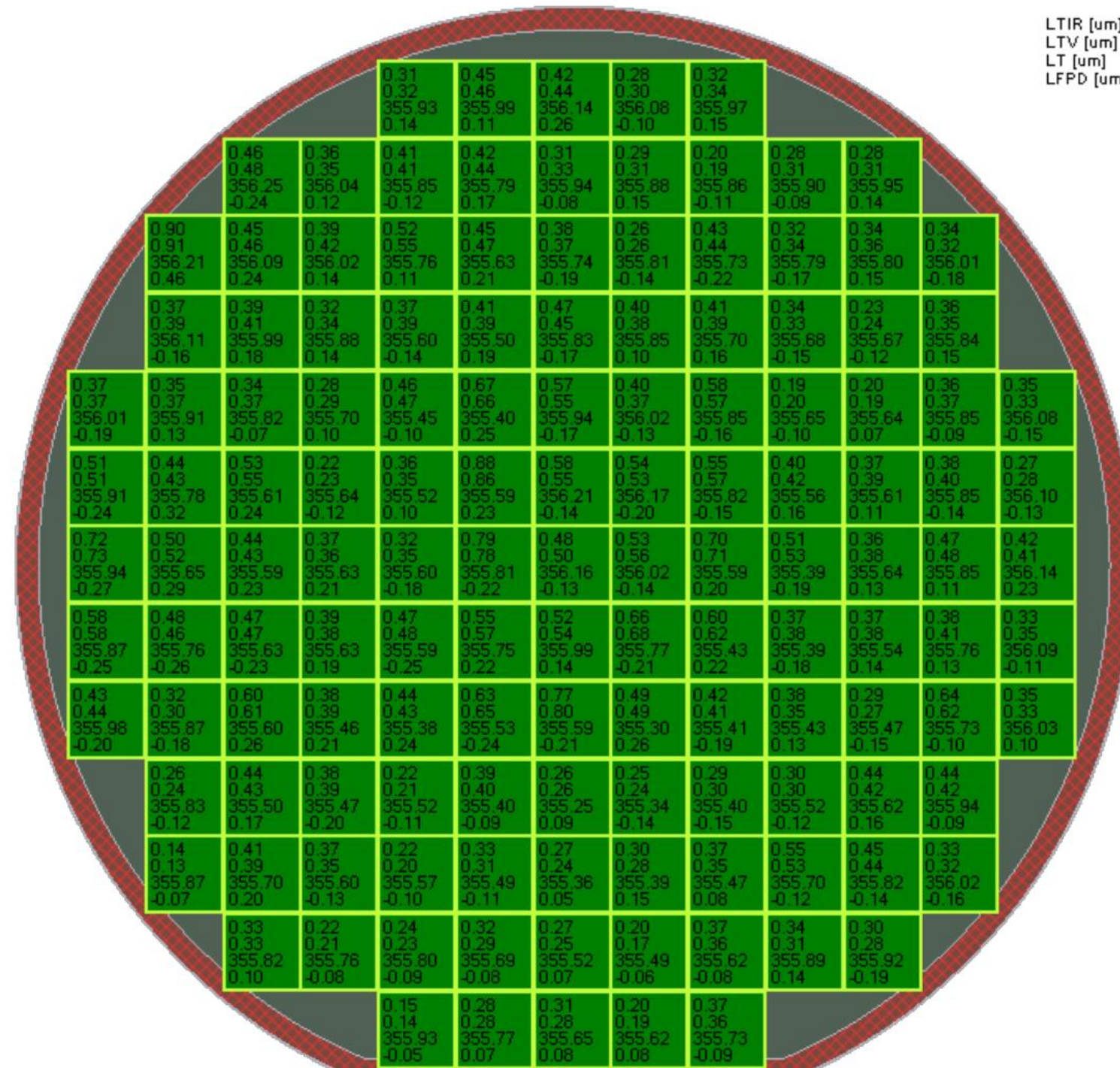

03设备介绍

EQUIPMENT INTRODUCTION

单面抛光机

01 高刚性、高压力
设备刚性好，运行稳定
36G设备可加载300kgf，50G设备可加载500kgf

02 防腐性能好
设备关键位置均做了防腐处理
可耐酸、耐碱，长期使用不锈损

03 独特的抛光盘面型控制工艺
36G抛光盘跳动 $\leq 10\mu\text{m}$ ，50G抛光盘跳动 $\leq 15\mu\text{m}$
可以根据工艺调整不同的盘型，实现最佳精度



TSP-910A



TSP-1270A

03设备介绍

EQUIPMENT INTRODUCTION

单面抛光机（分区加压&非分区加压）

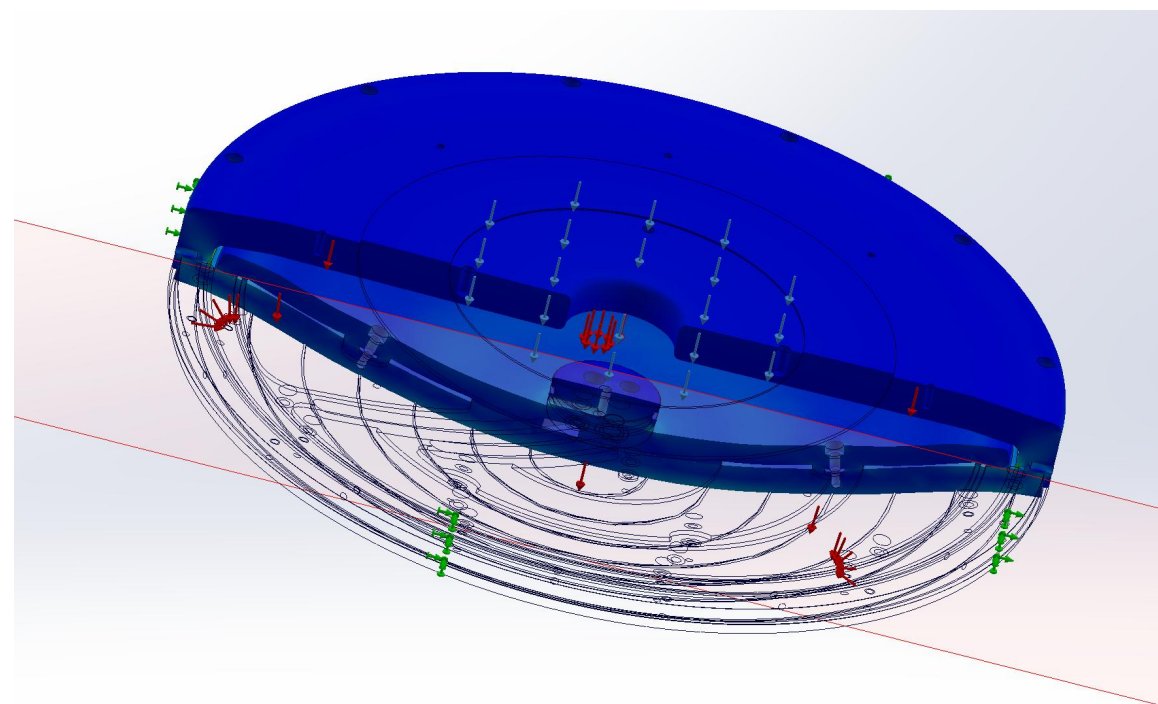

8英寸SiC晶圆

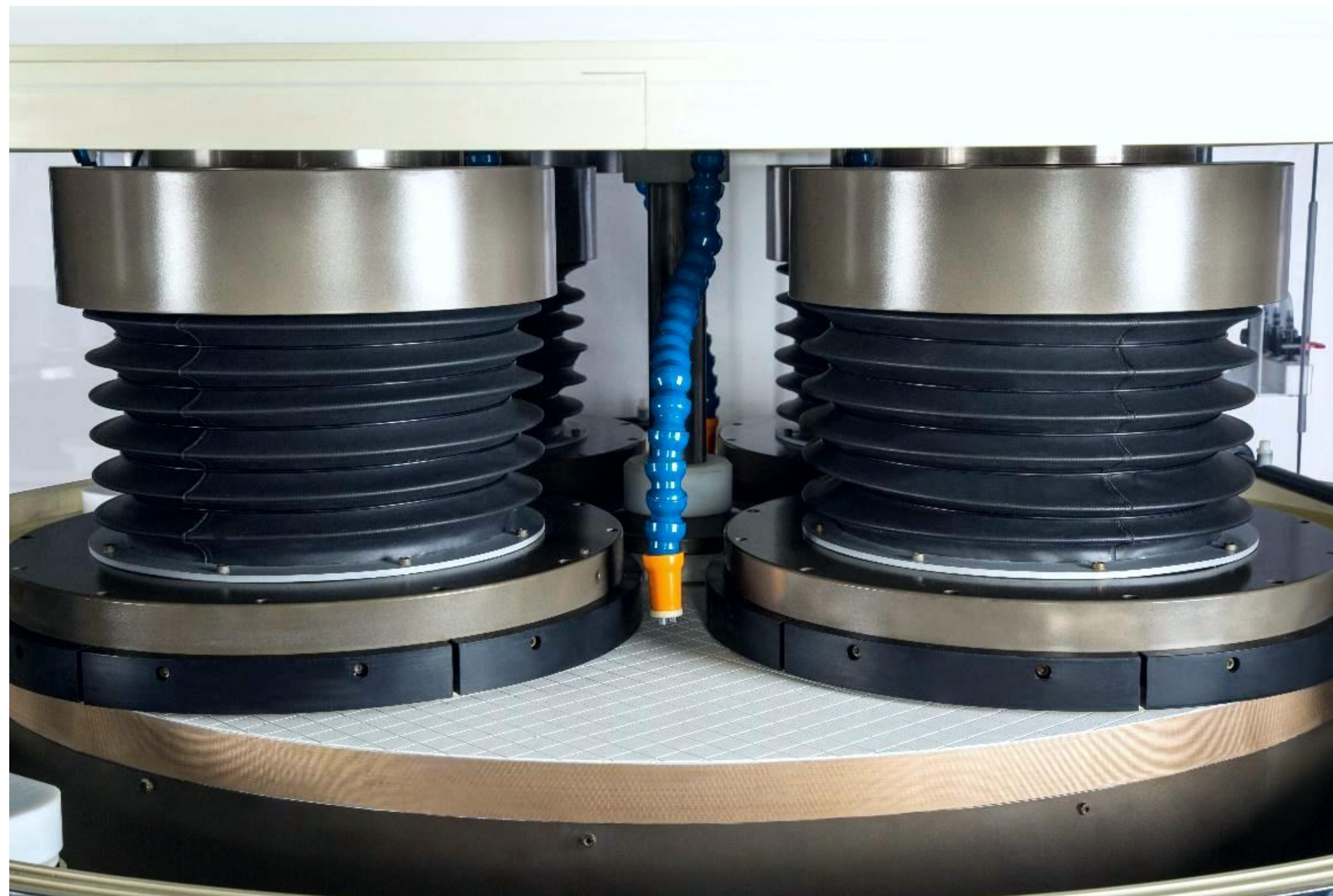

03设备介绍

EQUIPMENT INTRODUCTION

单面抛光机

SiC衬底单面抛光机

型号: TSP-910A

陶瓷盘规格: 360mm

6寸-3片/陶瓷盘*4陶瓷盘

最大6寸晶圆

TSP-1270A

485mm

6寸-6片/陶瓷盘*4陶瓷盘

8寸-3片/陶瓷盘*4陶瓷盘

适用范围

加工精度

工艺指标(精抛后)

6寸SiC衬底

粗糙度: $\leq R_a 0.1\text{nm}$

03设备介绍

EQUIPMENT INTRODUCTION

自动化方案:

1: 有蜡方案

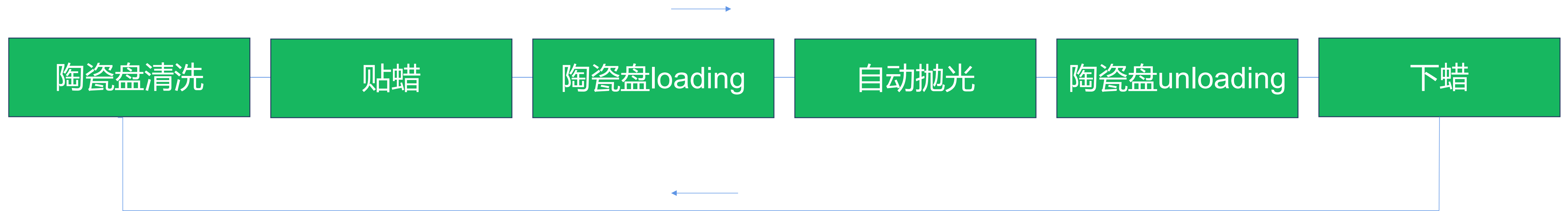

2: 无蜡方案

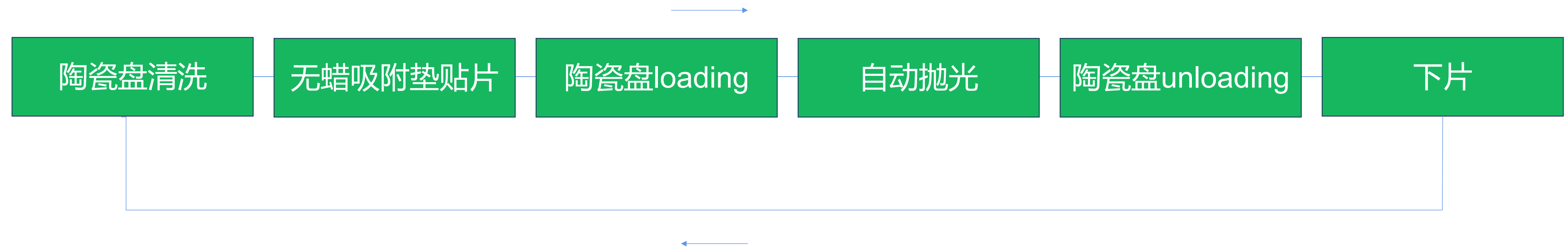

03设备介绍

EQUIPMENT INTRODUCTION

全自动陶瓷盘清洗机&贴蜡机



03设备介绍

EQUIPMENT INTRODUCTION

单面抛光机-自动上下料系统



03设备介绍

EQUIPMENT INTRODUCTION

晶锭全自动研磨机（配合激光剥离）



03设备介绍

EQUIPMENT INTRODUCTION

晶锭激光剥离自动化线

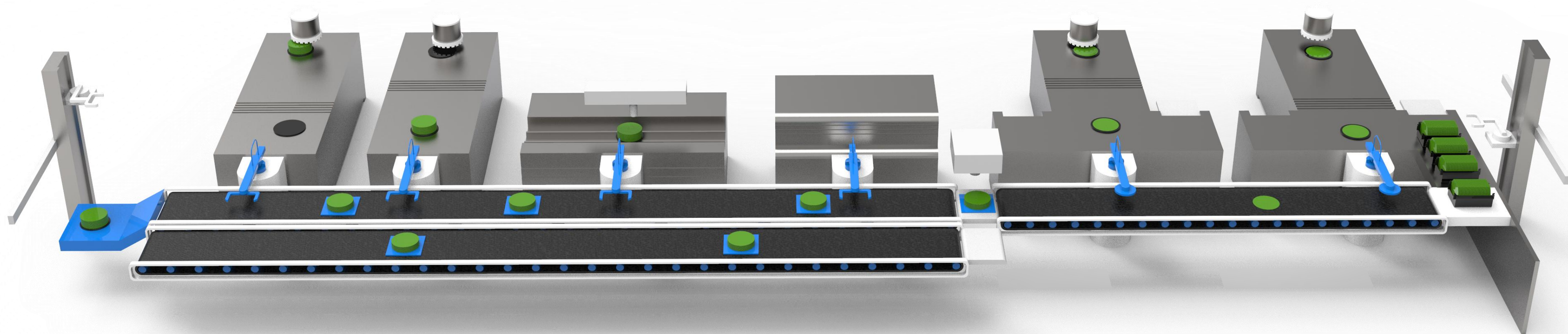

04 PART FOUR

特思迪优势

TSEMID ADVANTAGE



特思迪优势



技术专

已获得自主知识产权专利申请及授权100余项；主要产品核心部件均已国产化；多次承担国家级、省级重大课题研究，并荣获国家高新技术企业认定。



资历深

现有员工270人，本科及以上学历占比超过60%，技术研发人员70余人，研究生及以上学历20人。核心部门员工均由半导体行业从业经验10年以上。



配套全

深耕半导体材料超精度平面研磨、抛光技术,设备已经过多次迭代升级，精度高稳定性好，配套成熟的工艺，可提供系统解决方案和工艺设备。



占有率高

化合物半导体专用减薄、抛光、CMP装备国内唯一一家规模化量产企业，在化合物半导体领域市场占有率第一。

04特思迪优势

TSEMID ADVANTAGE

SiC衬底主要用户

- 天科合达
- 同光晶体
- 比亚迪
- 粤海金
- 微芯长江
- 科友半导体
- 晶越半导体
- 合盛新材料
- 弘元半导体
- 江苏集芯
- 天岳先进
- 山西烁科
- 三安
- 中电化合物
- 东尼半导体
- 超芯星
- 露笑半导体
- 眉山天乐
- 晶格领域
- 常州臻晶

合计超过400台

SiC器件主要用户

- 华为
- 泰科天润
- 方正微
- 长飞先进
- 芯科半导体
- 中电13所
- 中电55所
- 西电
- 中科院纳米所

合计超过30台

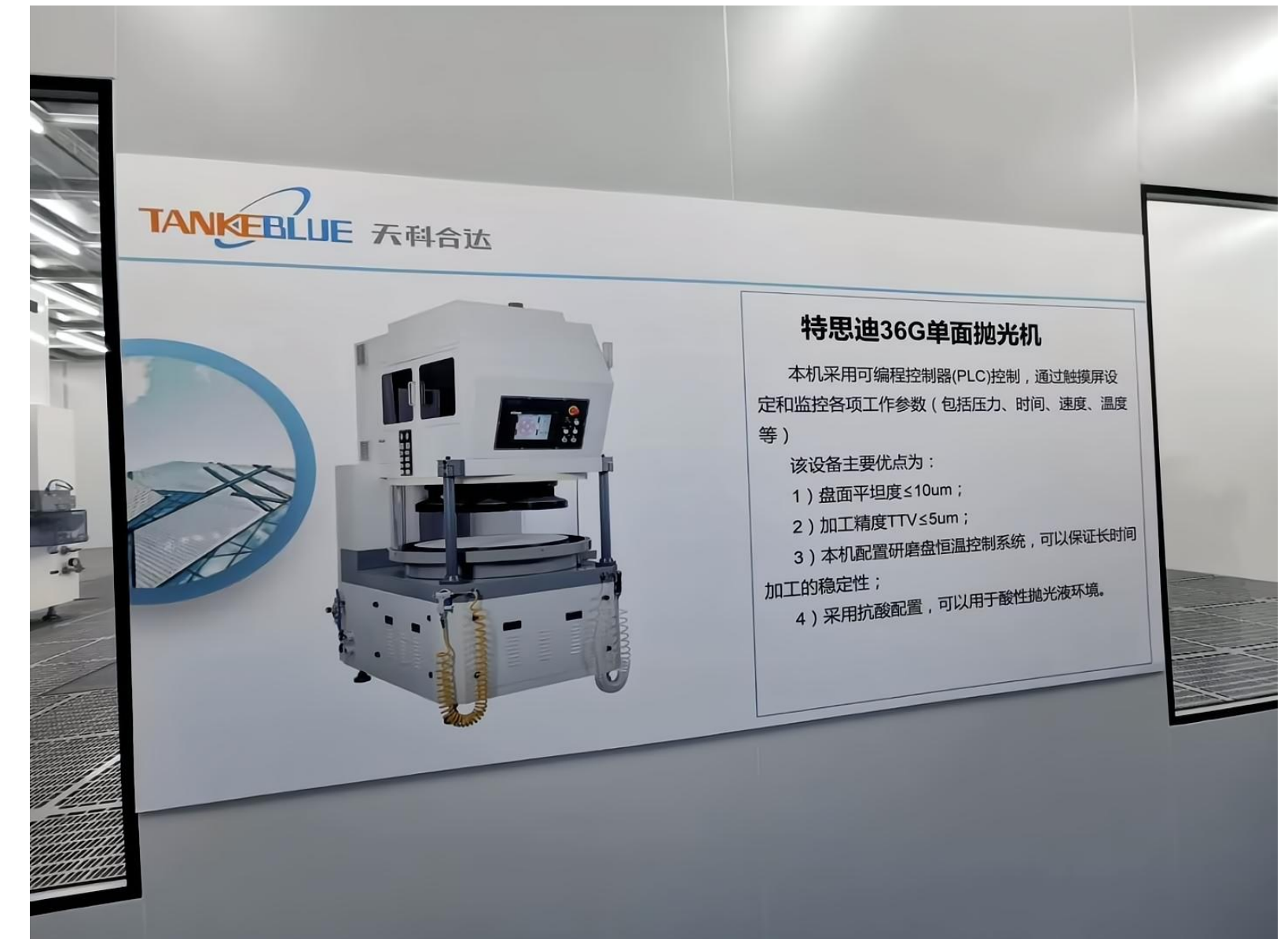

04特思迪优势

TSEMID ADVANTAGE

特思迪在北京、无锡、深圳分别成立技术服务中心，有熟练技术人员40余名，专门负责设备的安装调试和售后技术服务



服务响应

4小时内响应，24小时内到达现场

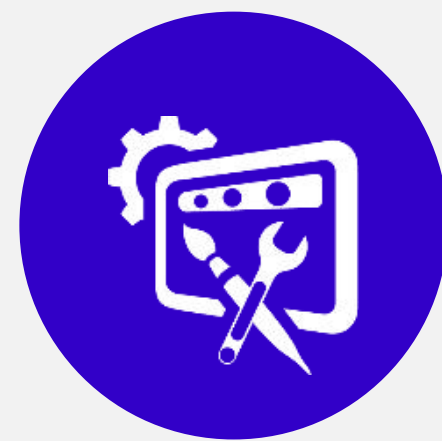

服务费用

在设备保修期内的，所有服务费用全免



备件仓库

在北京设有备件仓库，常用配件齐全

THANKS!

北京市顺义区杜杨北街3号

No.3 Duyang North Street, Shunyi District, Beijing

Tel:+86-10-6477 8430

E-mail: sales@tsd-semicon.com

www.tsd-semicon.com